



## NL0333 / NL1333 / NL2333

### Low power, Zero-Drift, High EMC Performance Rail-to-Rail I/O, Operational Amplifier

#### FEATURES

Low Input Offset Voltage	10μV max.
Zero-Drift	0.01μV/°C typ.
Low Supply Current	
NL0333/NL1333	17μA
NL2333	15μA/ch
Rail-to-Rail Input and Output	
Supply Voltage	2.1V to 5.5V
Input Bias Current	30pA
Gain Bandwidth Product	260kHz
Slew Rate	0.11V/μs
Equivalent Input Noise Voltage	60nV/√Hz
Integrated EMI Filter	
No phase-reversal	
CMOS Architecture	
Package:	SOT-23-5-DC, SC-88A-DB VSP-8-AF, EMP-8-AN

#### GENERAL DESCRIPTION

The NL0333/NL1333/NL2333 are single and dual rail-to-rail input and output single supply OpAmp featuring very low offset voltage (10μV max.) and zero-drift over temperature (0.01μV/°C typ.). Also features, low supply current, high-impedance rail-to-rail input, and rail-to-rail output that swings within 50 mV of the rails.

NLx333 series includes integrated EMI filter to reduce malfunctions caused by R<sub>F</sub> noises from mobile phones and other wireless devices.

NLx333 series operates from supply range of 2.1V to 5.5V and can operate from -40°C to 125°C temperature range. The NL0333 is available in 5-pin SOT-23 package. The NL1333 is available in 5-pin SC-88A package. The NL2333 is available in 8-pin VSP, and EMP package.

#### APPLICATIONS

- Battery-Powered Equipment
- Sensor Interface
- Temperature Sensors
- Current Sensing Amplifier

#### Precision Characteristics

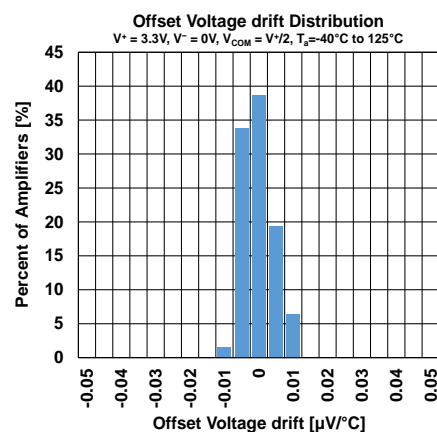
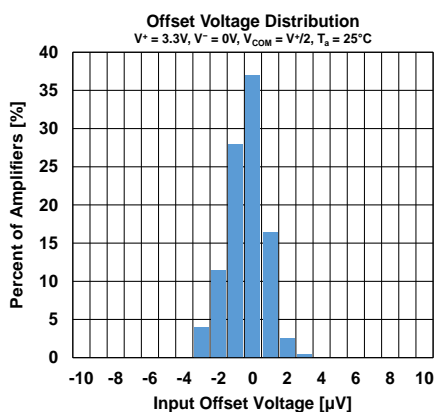

■ PRODUCT NAME INFORMATION

NLx333 aa A bb S

Description of configuration

Composition	Item	Description
x	Number of circuits	Indicates number of circuits. 0: Single 1: Single 2: Dual
aa	Package code	Indicates the package. DC: SOT-23-5-DC DB: SC-88A-DB AF: VSP-8-AF AN: EMP-8-AN
A	Version	Product version. A: Default
bb	Packing	Insert Direction. Refer to the packing specifications.
S	Grade	Indicates the quality grade. S: Standard

Grade

	Applications	Operating Temperature Range	Test Temperature
S	General-purpose and Consumer application	-40°C to 125°C	25°C

■ ORDER INFORMATION

Product Name	Package	RoHS	Halogen-Free	Plating Composition	Weight (mg)	Quantity (pcs/reel)
NL0333DCAE1S	SOT-23-5-DC	✓	✓	Sn2Bi	15	3000
NL1333DBAE1S	SC-88A-DB	✓	✓	Sn2Bi	7	3000
NL2333AFAE2S	VSP-8-AF	✓	✓	Sn2Bi	21	2000
NL2333ANAE2S	EMP-8-AN	✓	✓	Sn2Bi	76	2000

■ PIN DESCRIPTIONS (NL0333DC)

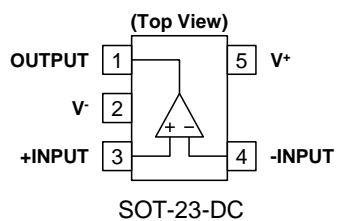

Pin No.	Pin Name	I/O	Description
1	OUTPUT	O	Output channel
2	V <sup>-</sup>	-	Negative supply or GND (single supply)
3	+INPUT	I	Non-inverting input channel
4	-INPUT	I	Inverting input channel
5	V <sup>+</sup>	-	Positive supply

■ PIN DESCRIPTIONS (NL1333DB)

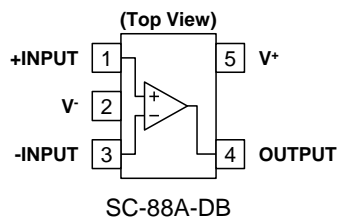

Pin No.	Pin Name	I/O	Description
1	+INPUT	I	Non-inverting input channel
2	V <sup>-</sup>	-	Negative supply or GND (single supply)
3	-INPUT	I	Inverting input channel
4	OUTPUT	O	Output channel
5	V <sup>+</sup>	-	Positive supply

■ PIN DESCRIPTIONS (NL2333AF)

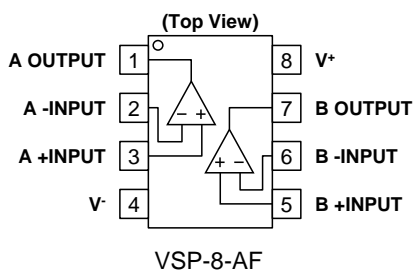

Pin No.	Pin Name	I/O	Description
1	A OUTPUT	O	Output channel A
2	A -INPUT	I	Inverting input channel A
3	A +INPUT	I	Non-inverting input channel A
4	V <sup>-</sup>	-	Negative supply or GND (single supply)
5	B +INPUT	I	Non-inverting input channel B
6	B -INPUT	I	Inverting input channel B
7	B OUTPUT	O	Output channel B
8	V <sup>+</sup>	-	Positive supply

■ PIN DESCRIPTIONS (NL2333AN)

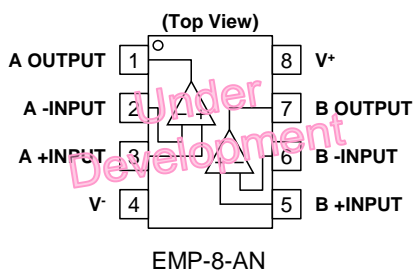

Pin No.	-INPUT	I/O	Inverting input channel
1	A OUTPUT	O	Output channel A
2	A -INPUT	I	Inverting input channel A
3	A +INPUT	I	Non-inverting input channel A
4	V-	-	Negative supply or GND (single supply)
5	B +INPUT	I	Non-inverting input channel B
6	B -INPUT	I	Inverting input channel B
7	B OUTPUT	O	Output channel B
8	V+	-	Positive supply

■ ABSOLUTE MAXIMUM RATINGS

	Symbol	Ratings	Unit
Supply Voltage $V_S = V^+ - V^-$	$V^+ - V^-$	7	V
Input Voltage <sup>*1</sup>	$V_{IN}$	$V^- - 0.3$ to $V^+ + 0.3$	V
Input Current <sup>*1</sup>	$I_{IN}$	$\pm 10$	mA
Output Terminal Input Voltage <sup>*2</sup>	$V_O$	$V^- - 0.3$ to $V^+ + 0.3$	V
Differential Input Voltage <sup>*3</sup>	$V_{ID}$	$\pm 7$	V
Output Short-Circuit Duration <sup>*4</sup>		Continuous	
Storage Temperature Range	$T_{stg}$	-55 to 150	°C
Junction Temperature <sup>*5</sup>	$T_j$	150	°C

<sup>\*1</sup> Input voltages outside the supply voltage will be clamped by ESD protection diodes. If the input voltage exceeds the supply voltage, the current must be limited 10 mA or less by using a restriction resistance. Input current inflow is positive and Input current outflow is negative.

<sup>\*2</sup> The output terminal input voltage is limited at 7V.

<sup>\*3</sup> Differential voltage is the voltage difference between +INPUT and -INPUT.

<sup>\*4</sup> Power loss increases when output is short-circuited; do not exceed  $T_j$ .

<sup>\*5</sup> Calculate the power consumption of the IC from the operating conditions, and calculate the junction temperature with the thermal resistance.

Please refer to "Thermal characteristics" for the thermal resistance under our measurement board conditions.

**ABSOLUTE MAXIMUM RATINGS**

Electronic and mechanical stress momentarily exceeded absolute maximum ratings may cause permanent damage and may degrade the lifetime and safety for both device and system using the device in the field. The functional operation at or over these absolute maximum ratings is not assured.

■ THERMAL CHARACTERISTICS

Package	Measurement Result <sup>*1</sup>		Unit
	$\theta_{ja}$	$\psi_{jt}$	
SOT-23-5-DC	192	58	°C/W
SC-88A-DB	255	73	
VSP-8-AF	170	39	
EMP-8-AN	125	27	

$\theta_{ja}$ : Junction-to-Ambient Thermal Resistance

$\psi_{jt}$ : Junction-to-Top Thermal Characterization Parameter

<sup>\*1</sup> Mounted on glass epoxy board (76.2 mm x 114.3 mm x 1.6 mm: based on EIA/JEDEC standard, 4-layer FR-4), internal Cu area: 74.2 mm x 74.2 mm.

■ ELECTROSTATIC DISCHARGE (ESD) PROTECTION VOLTAGE

	Conditions	Protection Voltage
HBM	C = 100 pF, R = 1.5 kΩ	±2000V
CDM		±1000V

**ELECTROSTATIC DISCHARGE RATINGS**

The electrostatic discharge test is done based on JEDEC JS001 and JS002.  
 In the HBM method, ESD is applied using the power supply pin and GND pin as reference pins.

■ RECOMMENDED OPERATING CONDITIONS

	Symbol	Ratings	Unit
Supply Voltage	V <sup>+</sup> - V <sup>-</sup>	2.1 to 5.5	V
Operating Temperature Range	T <sub>a</sub>	-40 to 125	°C

**RECOMMENDED OPERATING CONDITIONS**

All of electronic equipment should be designed that the mounted semiconductor devices operate within the recommended operating conditions. The semiconductor devices cannot operate normally over the recommended operating conditions, even if they are used over such conditions by momentary electronic noise or surge. And the semiconductor devices may receive serious damage when they continue to operate over the recommended operating conditions.

■ BLOCK DIAGRAM

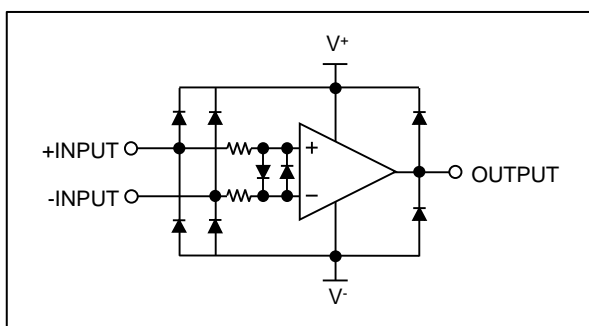

### ■ ELECTRICAL CHARACTERISTICS (NL0333/NL1333)

$V^+ = 2.1V$  to  $5.5V$ ,  $V^- = 0V$ ,  $V_{COM} = V^+/2$ ,  $R_L = 10k\Omega$  to  $V_{COM}$ ,  $T_a = 25^\circ C$ , unless otherwise specified.

Parameter	Symbol	Conditions	MIN	TYP	MAX	Unit
<b>INPUT CHARACTERISTICS</b> *1						
Input Offset Voltage	$V_{IO}$	$V^+ = 3.3V$	-	2	10	$\mu V$
Input Offset Voltage Drift	$\Delta V_{IO}/\Delta T$	$T_a = -40^\circ C$ to $125^\circ C$	-	0.01	-	$\mu V/^\circ C$
Input Bias Current	$I_B$	$T_a = -40^\circ C$ to $125^\circ C$	-	30	-	$\mu A$
Input Offset Current	$I_{IO}$		-	70	-	$\mu A$
Open-Loop Voltage Gain	$A_V$	$V_O = V^- + 0.1V$ to $V^+ - 0.1V$ , $R_L = 10k\Omega$ to $V^+/2$	106	130	-	dB
Common-Mode Rejection Ratio	CMR	$V_{COM} = V^-$ to $V^+$	106	130	-	dB
Common-Mode Input Voltage Range	$V_{ICM}$	CMR $\geq 106$ dB	$V^-$	-	$V^+$	V
<b>OUTPUT CHARACTERISTICS</b>						
High-level Output Voltage ( $V^+ - V_O$ )	$V_{OH}$	$V^+ = 2.1V, 5.5V, R_L = 10k\Omega$ to $V^+/2$	-	30	50	mV
Low-level Output Voltage	$V_{OL}$	$V^+ = 2.1V, 5.5V, R_L = 10k\Omega$ to $V^+/2$	-	30	50	mV
Capacitive Load Drive	$C_L$	$\Phi_M = 45$ deg	-	500	-	pF
Output Impedance	$Z_O$	$V^+ = 5V, f = 260kHz$	-	3	-	k $\Omega$
Output Short-Circuit Current	$I_{SC}$	$V^+ = 5V, \text{Source / Sink}$	-	17	-	mA
<b>POWER SUPPLY</b>						
Supply Current	$I_{SUPPLY}$	$V^+ = 5V, V_{COM} = V^-$	-	17	25	$\mu A$
Supply Voltage Rejection Ratio	SVR	$V^+ = 2.1$ to $5.5V$	106	120	-	dB
<b>AC CHARACTERISTICS</b>						
Slew Rate	SR	$C_L = 10pF, V_{IN} = 4V_{PP}, G_V = 1$	-	0.11	-	V/ $\mu s$
Gain Bandwidth Product	GBW	$R_L = 100k\Omega, C_L = 10pF, f = 10kHz$	-	260	-	kHz
Phase Margin	$\Phi_M$	$C_L = 10pF$ $C_L = 500pF$	-	60	-	Deg
Equivalent Input Noise Voltage	$V_{NI}$	$f = 0.1$ to $10Hz$	-	45	-	Deg
Equivalent Input Noise Voltage	$e_n$	$f = 10Hz$	-	1.2	-	$\mu V_{PP}$
Equivalent Input Noise Current	$I_n$	$f = 10Hz$	-	60	-	nV/ $\sqrt{Hz}$
			-	100	-	fA/ $\sqrt{Hz}$

\*1 Input offset voltage and drift, Input bias and offset current are positive or negative, its absolute values are listed in electrical characteristics.

## ■ ELECTRICAL CHARACTERISTICS (NL2333)

$V^+ = 2.1V$  to  $5.5V$ ,  $V^- = 0V$ ,  $V_{COM} = V^+/2$ ,  $R_L = 10k\Omega$  to  $V_{COM}$ ,  $T_a = 25^\circ C$ , unless otherwise specified.

Parameter	Symbol	Conditions	MIN	TYP	MAX	Unit
<b>INPUT CHARACTERISTICS</b> *1						
Input Offset Voltage	$V_{IO}$	$V^+ = 3.3V$	-	2	10	$\mu V$
Input Offset Voltage Drift	$\Delta V_{IO}/\Delta T$	$T_a = -40^\circ C$ to $125^\circ C$	-	0.01	-	$\mu V/^\circ C$
Input Bias Current	$I_B$	$T_a = -40^\circ C$ to $125^\circ C$	-	30	-	$\mu A$
Input Offset Current	$I_{IO}$		-	70	-	$\mu A$
Open-Loop Voltage Gain	$A_V$	$V_O = V^- + 0.1V$ to $V^+ - 0.1V$ , $R_L = 10k\Omega$ to $V^+/2$	106	130	-	dB
Common-Mode Rejection Ratio	CMR	$V_{COM} = V^-$ to $V^+$	106	130	-	dB
Common-Mode Input Voltage Range	$V_{ICM}$	CMR $\geq 106$ dB	$V^-$	-	$V^+$	V
<b>OUTPUT CHARACTERISTICS</b>						
High-level Output Voltage ( $V^+ - V_O$ )	$V_{OH}$	$V^+ = 2.1V, 5.5V, R_L = 10k\Omega$ to $V^+/2$	-	30	50	mV
Low-level Output Voltage	$V_{OL}$	$V^+ = 2.1V, 5.5V, R_L = 10k\Omega$ to $V^+/2$	-	30	50	mV
Capacitive Load Drive	$C_L$	$\Phi_M = 45$ deg	-	500	-	pF
Output Impedance	$Z_O$	$V^+ = 5V, f = 260kHz$	-	3	-	k $\Omega$
Output Short-Circuit Current	$I_{SC}$	$V^+ = 5V, \text{Source / Sink}$	-	17	-	mA
<b>POWER SUPPLY</b>						
Supply Current per Amplifier	$I_{SUPPLY}$	$V^+ = 5V, V_{COM} = V^-$	-	15	23	$\mu A$
Supply Voltage Rejection Ratio	SVR	$V^+ = 2.1$ to $5.5V$	106	120	-	dB
<b>AC CHARACTERISTICS</b>						
Slew Rate	SR	$C_L = 10pF, V_{IN} = 4V_{PP}, G_V = 1$	-	0.11	-	V/ $\mu s$
Gain Bandwidth Product	GBW	$R_L = 100k\Omega, C_L = 10pF, f = 10kHz$	-	260	-	kHz
Phase Margin	$\Phi_M$	$C_L = 10pF$ $C_L = 500pF$	-	60	-	Deg
Equivalent Input Noise Voltage	$V_{NI}$	$f = 0.1$ to $10Hz$	-	1.2	-	$\mu V_{PP}$
Equivalent Input Noise Voltage	$e_n$	$f = 10Hz$	-	60	-	nV/ $\sqrt{Hz}$
Equivalent Input Noise Current	$I_n$	$f = 10Hz$	-	100	-	fA/ $\sqrt{Hz}$
Channel Separation	CS	$f = 10Hz$	-	140	-	dB

\*1 Input offset voltage and drift, Input bias and offset current are positive or negative, its absolute values are listed in electrical characteristics.

■ TYPICAL CHARACTERISTICS

Note: Typical Characteristics are intended to be used as reference data; they are not guaranteed.

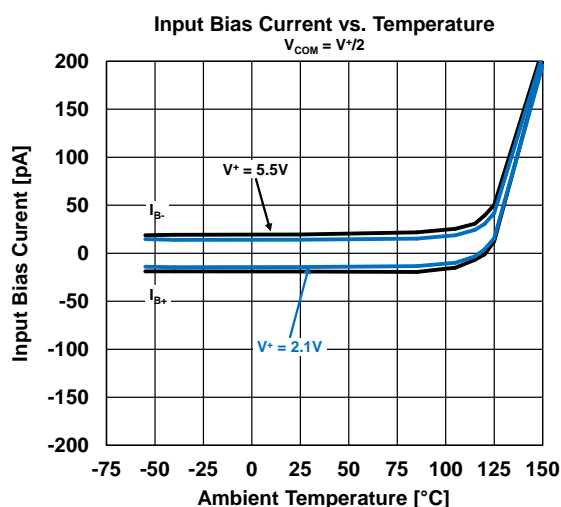
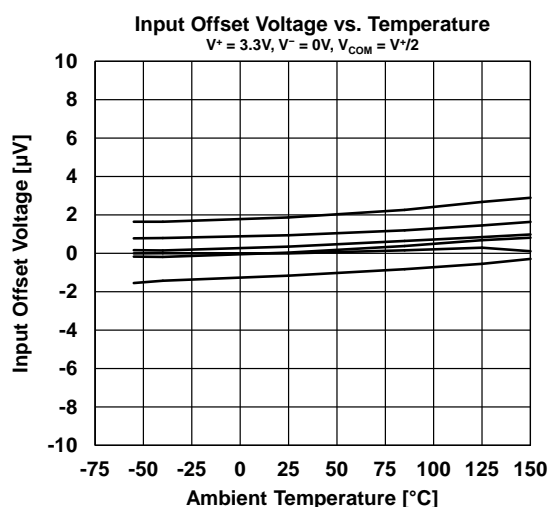
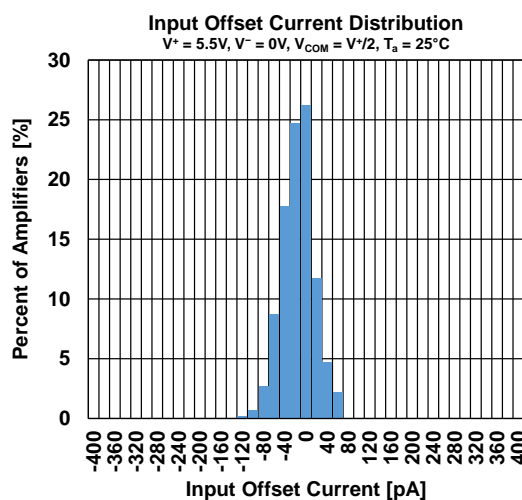
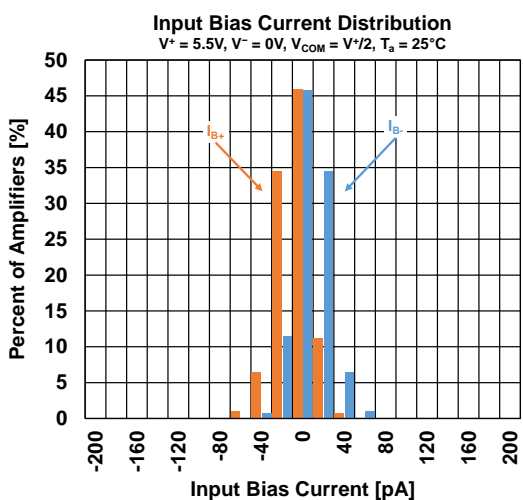
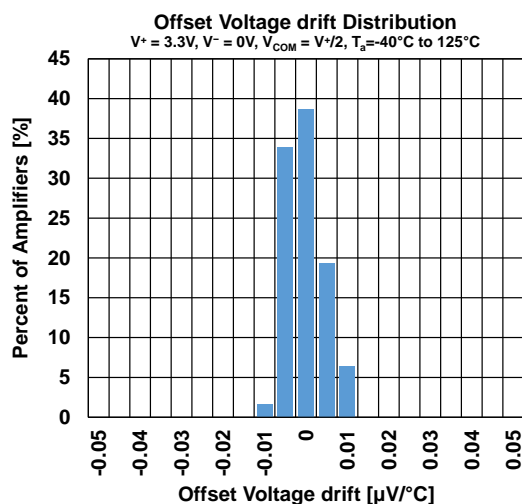
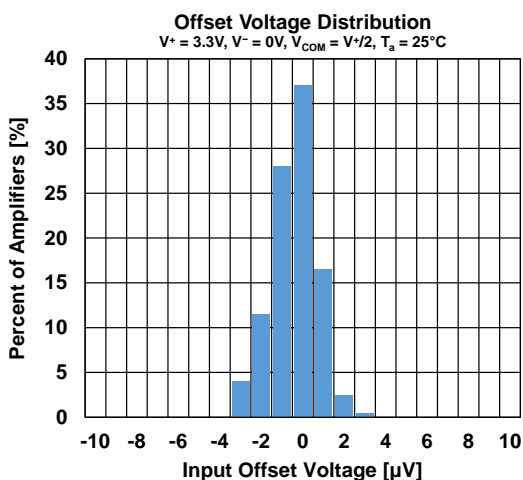

■ TYPICAL CHARACTERISTICS

Note: Typical Characteristics are intended to be used as reference data; they are not guaranteed.

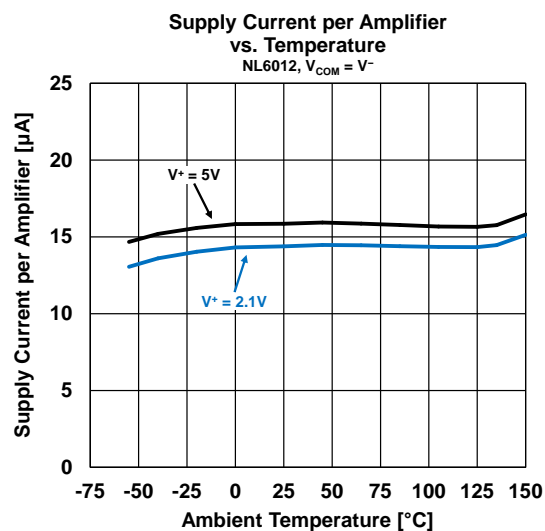
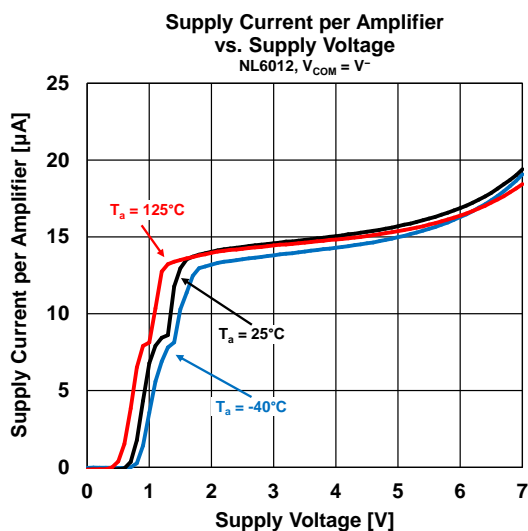
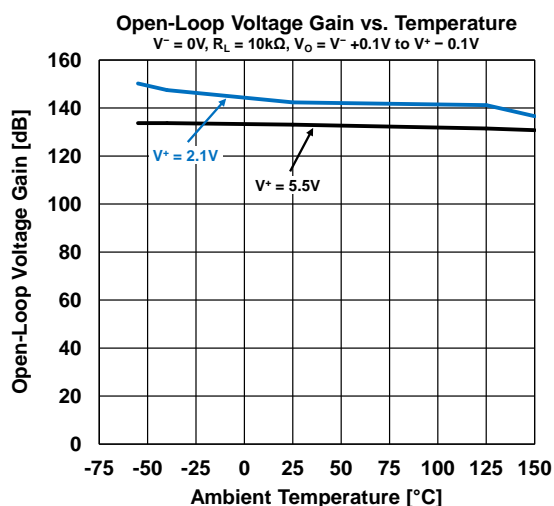
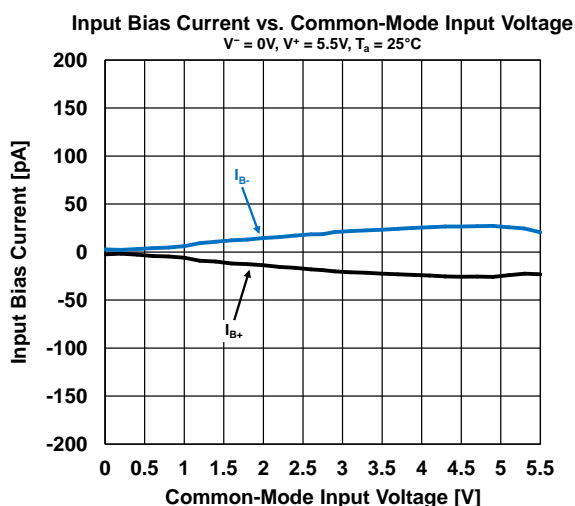
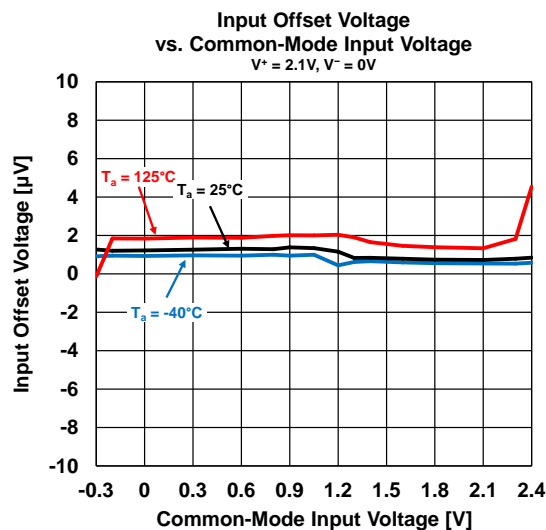
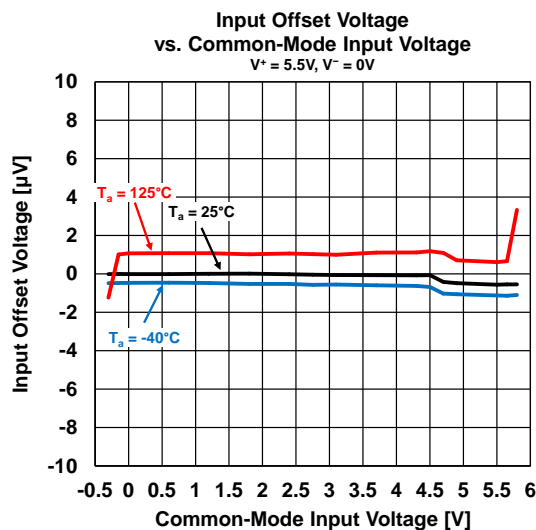

■ TYPICAL CHARACTERISTICS

Note: Typical Characteristics are intended to be used as reference data; they are not guaranteed.

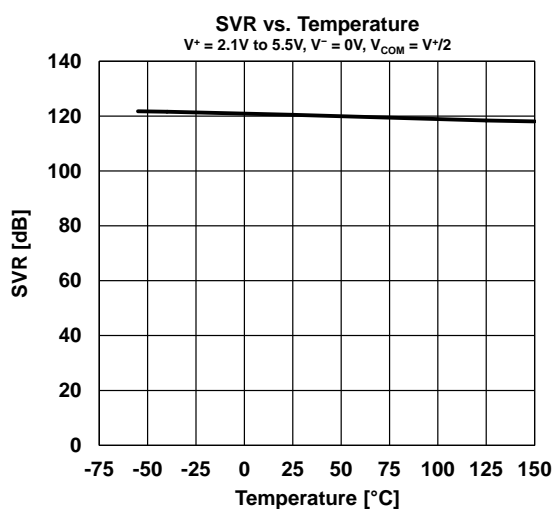
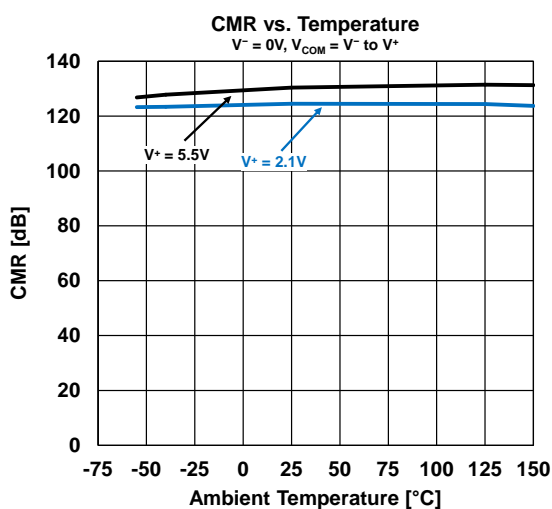
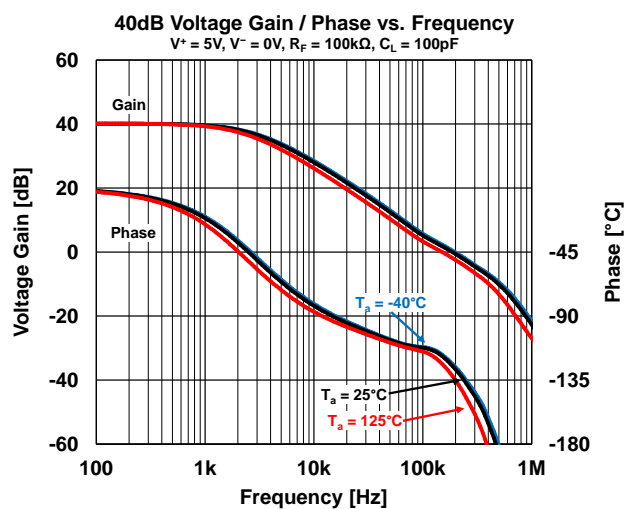
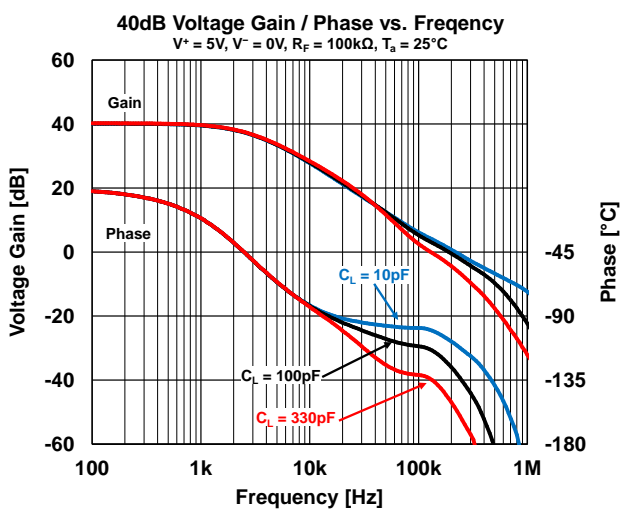
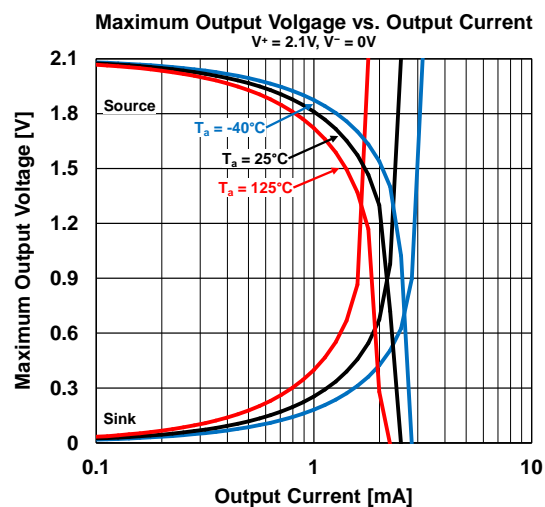
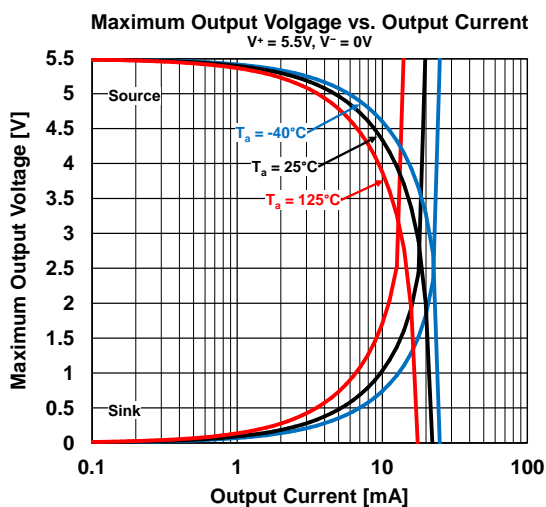

■ TYPICAL CHARACTERISTICS

Note: Typical Characteristics are intended to be used as reference data; they are not guaranteed.

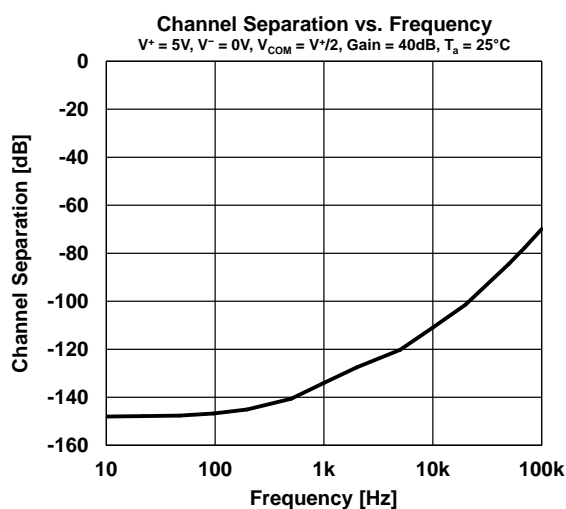
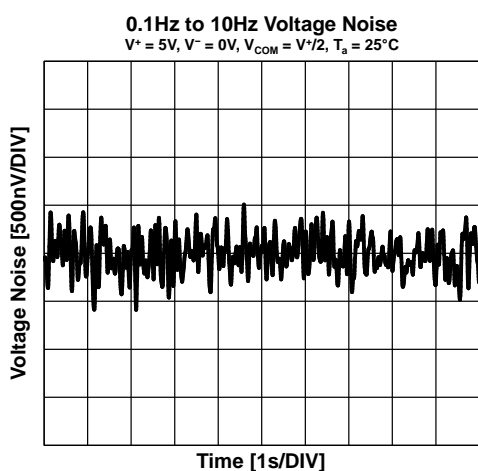
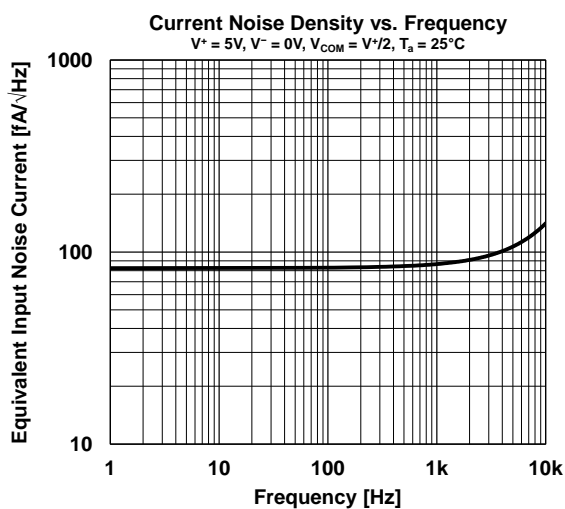
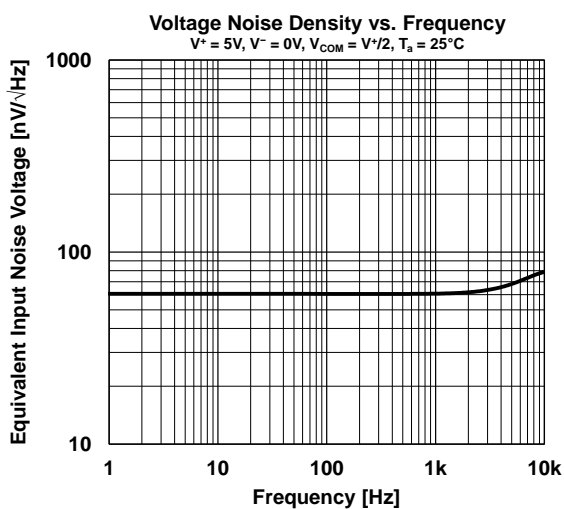
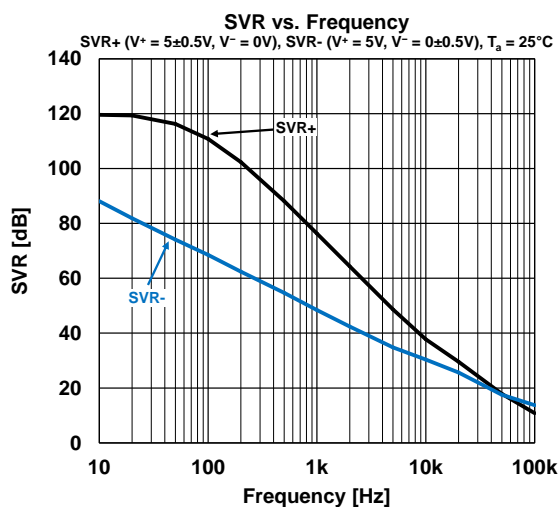
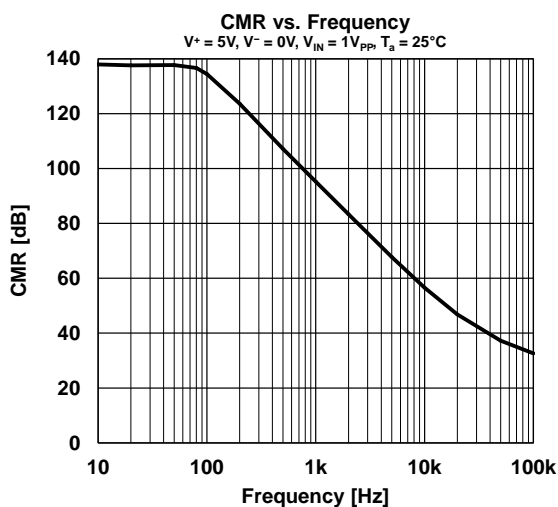

■ TYPICAL CHARACTERISTICS

Note: Typical Characteristics are intended to be used as reference data; they are not guaranteed.

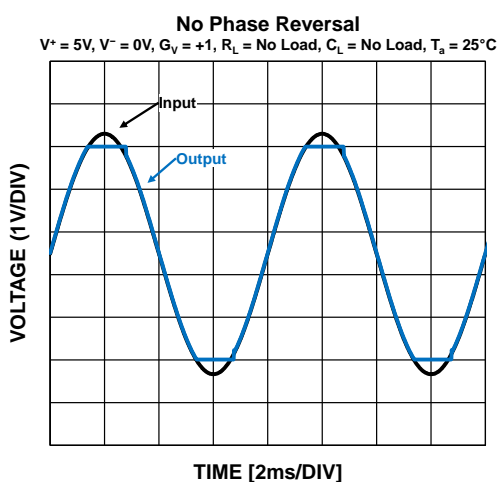
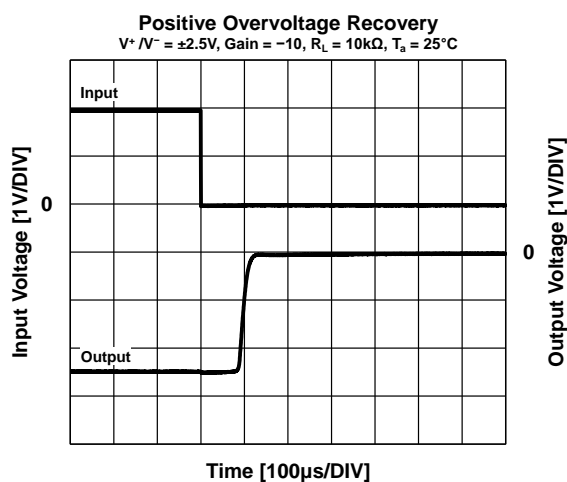
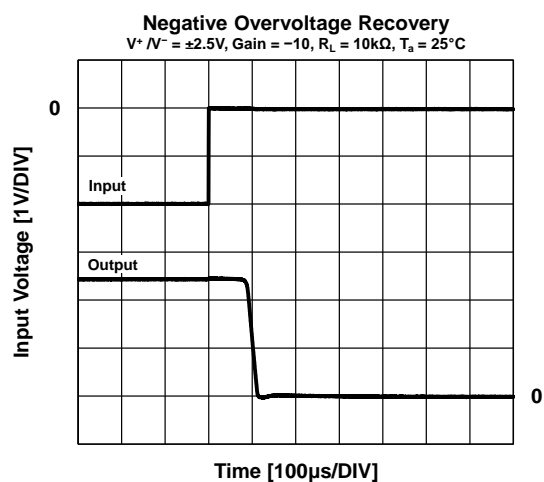
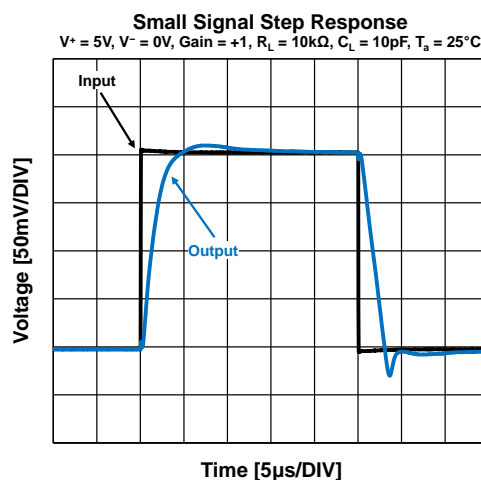
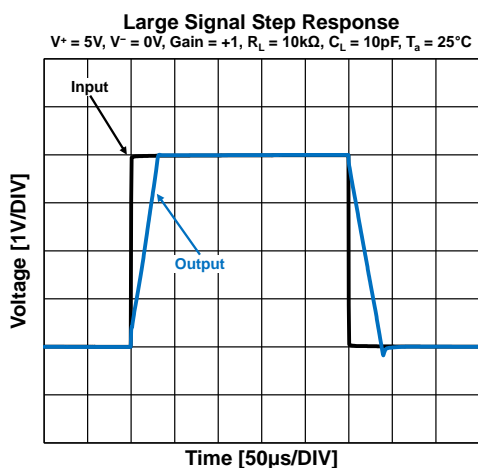

■ TEST CIRCUITS

- $I_{SUPPLY}$ ,  $V_{IO}$ , CMR, SVR  
 $R_G = 50\Omega$ ,  $R_F = 500k\Omega$

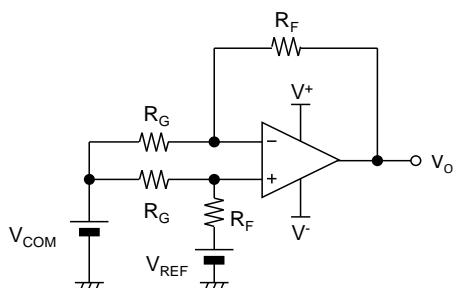

$$V_{IO} = \frac{R_G}{(R_G + R_F)} \times (V_O - V_{REF})$$

$$CMR = 20 \log \frac{\Delta V_{COM} \left(1 + \frac{R_F}{R_G}\right)}{\Delta V_O}$$

$$SVR = 20 \log \frac{\Delta V_S \left(1 + \frac{R_F}{R_G}\right)}{\Delta V_O}$$

$$V_S = V^+ - V^-$$

$$V_{REF} = V_S / 2$$

- $V_{OH}$ ,  $V_{OL}$

$$V_{OH}; V_{ID} = -0.1V, V_{COM} = V^+ / 2$$

$$V_{OL}; V_{ID} = 0.1V, V_{COM} = V^+ / 2$$

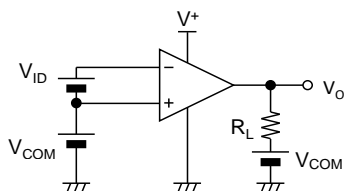

- GBW

$$R_G = 1k\Omega, R_F = 100k\Omega$$

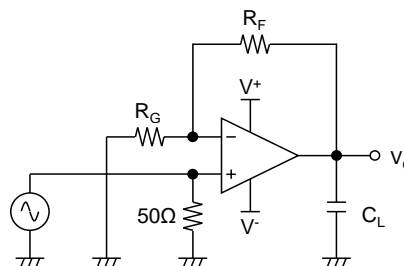

- SR

$$R_L = 10k\Omega$$

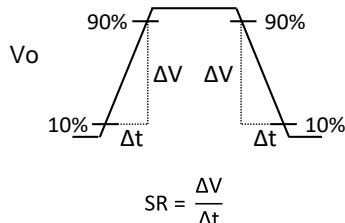
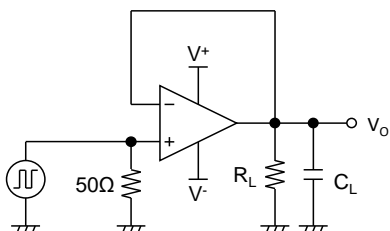

## ■ APPLICATION NOTES

### Overview of Zero Drift Operation

The NLx333 series zero-drift OpAmps use a chopper stabilized architecture. A simplified functional block is shown in Figure 1.

The amplifier consists of two signal paths, the signal path consisting of GM1 is dominant at low frequencies and compensates for input offset voltage and 1/f noise.

Chop1/Chop2 are controlled by a clock signal of approximately 100 kHz, modulating the DC offset voltage and 1/f noise of GM1 to high frequencies. The modulated high-frequency component is controlled by a filter in the next stage.

The signal path consisting of GM<sub>2</sub> is dominant at high frequencies, resulting in stable operation at high frequencies.

Each signal path is internally summed.

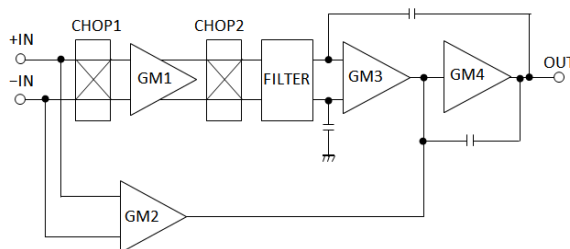

Figure 1. Functional block

### Use of Precision Operational Amplifiers

The NLx333 series has a low offset voltage (10 $\mu$ V) and zero-drift (0.05 $\mu$ V/ $^{\circ}$ C) characteristics. Achieve a high performance, take care about thermoelectric effect possibly occurs on each input terminal. Generally, if there are thermal mismatches at the junction of different types of metals, the thermoelectric voltage (Seebeck effect) occurs at the junction.

### Thermoelectric effect (Seebeck effect)

Thermoelectromotive forces are generated by temperature gradients in the presence of dissimilar metal contacts such as relays and switches. The thermoelectromotive force difference between both input terminals is output as an input offset voltage.

To reduce the influence of the thermal electromotive force on the input offset voltage, it is useful to ensure that equal thermal electromotive forces are generated at both input terminals.

### Bypassing power supply

To provide a stable supply voltage with low noise to the operational amplifier, connect the bias capacitor as close to the power supply pin as possible.

### Single and Dual Supply Voltage Operation

The NLx333 series works with both single supply and dual supply when the voltage supplied is between V<sup>+</sup> and V<sup>-</sup>. These amplifiers operate from single 2.1 to 5.5V supply and dual  $\pm$ 1.05V to  $\pm$ 2.75V supply.

### Power-on Time

Figure 2 shows the NLx333 series power-on time. Power-on time depends on the supply voltage, bypass capacitor, impedance of supply source and impedance other devices. While settling time, IC is unstable, such as output voltage.

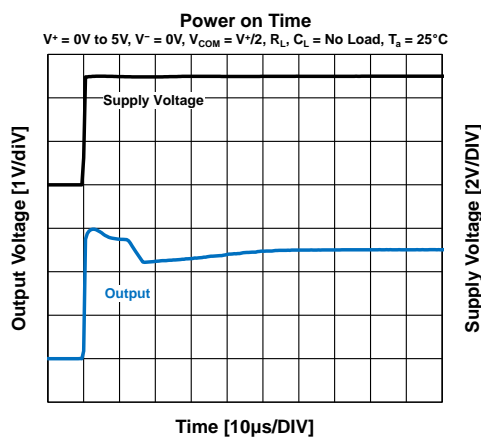

Figure 2. Power-on time

**No Phase Reversal**

The NLx333 series are designed to prevent phase reversal at the input voltage above the supply voltage. Figure 3 shows no phase reversal characteristics with the input voltage exceeding the supply voltage.

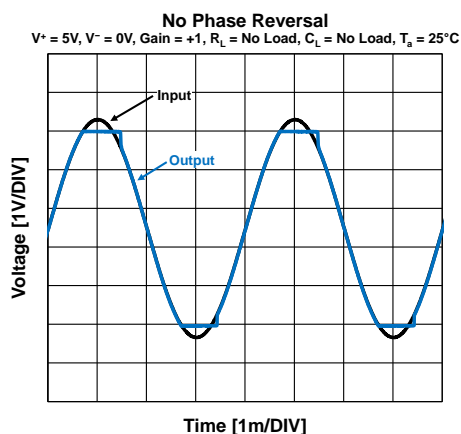

Figure 3. No phase reversal

**Input differential voltage**

The typical input bias current of the NLx333 during normal operation is approximately 30 pA. However, in overdrive conditions with large input differential voltages, the bias current can increase significantly (Figure 4).

The input differential voltage activates the parasitic diodes in the chopping switch, which in combination with the electromagnetic interference (EMI) filter resistors form the equivalent circuit shown in Figure 5.

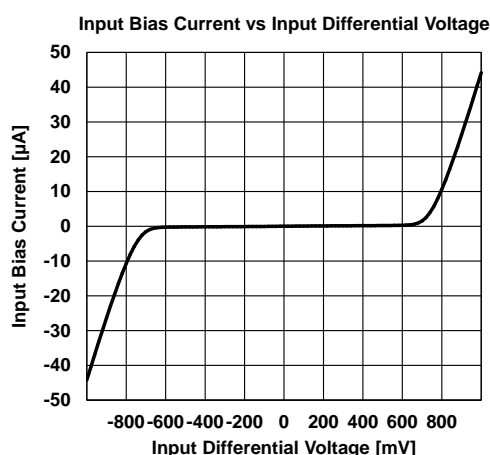

Figure 4. Input bias current

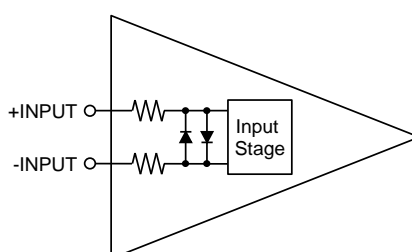

Figure 5. Equivalent input circuit

### Input Voltage Exceeding the Supply Voltage

Inputs of the NLx333 series are protected by ESD diodes that will conduct if the input voltages exceed the power supplies by more than approximately 300mV. Momentary voltages greater than 300mV beyond the power supply, inputs can be tolerated if the current is limited to 10mA. Figure 6 is easily accomplished with an input resistor. If the input voltage exceeds the supply voltage, the input current must be limited 10mA or less by using a restriction resistance (RLIMIT) as shown in Figure 6.

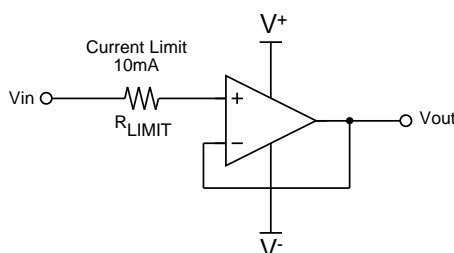

Figure 6. Example of input protection

### Capacitive Load

The NLx333 series can use at unity gain follower, but the unity gain follower is the most sensitive configuration to capacitive loading. The combination of capacitive load placed directly on the output of an amplifier along with the output impedance of the amplifier creates a phase lag which in turn reduces the phase margin of the amplifier. If phase margin is significantly reduced, the response will cause overshoot and ringing in the step response. The NLx333 series is unity gain stable for capacitive loads of 1000pF. To drive heavier capacitive loads, an isolation resistor,  $R_{ISO}$  as shown Figure 7, should be used.  $R_{ISO}$  improves the feedback loop's phase margin by making the output load resistive at higher frequencies. The larger the value of  $R_{ISO}$ , the more stable the output voltage will be. However,

larger values of  $R_{ISO}$  result in reduced output swing, reduced output current drive and reduced frequency bandwidth. Figure 8 shown in gain peaking characteristics.

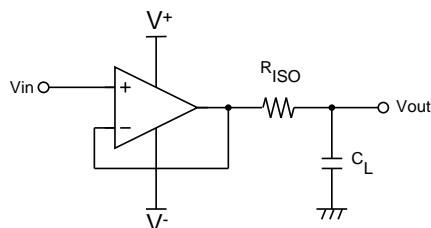

Figure 7. Isolating capacitive load

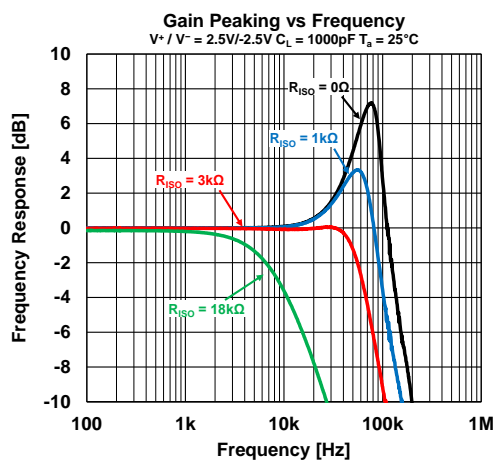

Figure 8. Gain peaking with  $R_{ISO}$

**Terminating unused OpAmps**

Examples of common methods of terminating an uncommitted OpAmp are shown in Figure 9. Improper termination can be result increase supply current, heating and noise in OpAmps.

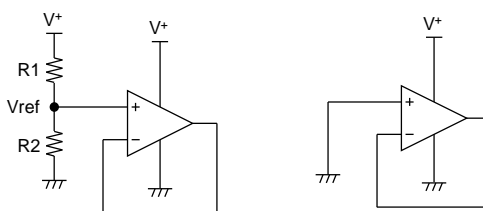
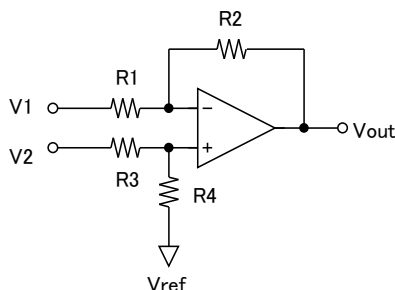

Figure 9. Terminating unused OpAmps

**Differential Amplifier**

Figure10 shows a one OpAmp differential amplifier that consists of the single OpAmp and four external resistors. Differential amplifier amplifies the difference between its two input pins, and rejects the common-mode input voltage at both input pins. This is used in variety of applications including current sensing, differential to single-end converter, isolation amplifier to remove common-mode noise.



$$V_{out} = \left(\frac{R1+R2}{R3+R4}\right) \frac{R4}{R1} V2 - \frac{R2}{R1} V1 + \left(\frac{R1+R2}{R3+R4}\right) \frac{R3}{R1} V_{ref}$$

$$R1=R3, R2=R4$$

$$V_{out} = \frac{R2}{R1} (V2 - V1) + V_{ref}$$

Figure 10. Differential Amplifier

The differential amplifier's common-mode rejection ratio (CMR) is primarily determined by resistor mismatches, not by the OpAmp's CMR. Ideally, the resistors are chosen such that  $R2/R1 = R4/R3$ . The CMR due to the resistors in differential amplifier can be calculated using the below formula:

$$CMR_{R\_error} \approx 20 \log \left( \frac{1 + \frac{R2}{R1}}{4 R_{error}} \right)$$

$$CMR_{R\_error} = \text{CMR due only to the resistors}$$

$$R_{error} = \text{Resistor's tolerance}$$

Example:

$$R2 / R1 = 1 \text{ and } R_{error} = 0.1\%, \text{ then } CMR = 54\text{dB}$$

$$R2 / R1 = 1 \text{ and } R_{error} = 1\%, \text{ then } CMR = 34\text{dB}$$

If using resistors with 1% tolerance and gain = 1, the CMR will only be 34dB.

**Instrumentation Amplifier**

The instrumentation amplifier is suitable for requiring high input impedance and high common mode noise rejection at high gains. Figure11 and Figure12 is instrumentation amplifier using two or three OpAmp. Supply the reference voltage ( $V_{ref}$ ) with a low impedance source to keep accuracy.

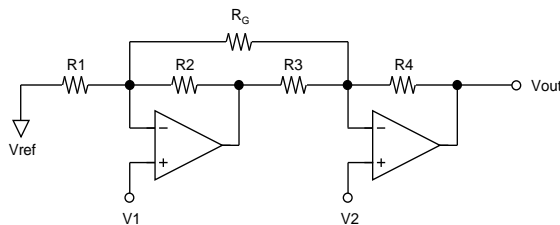

$$V_{out} = \left(1 + \frac{R_4}{R_3} + \frac{2R_4}{R_G}\right) (V_2 - V_1) + V_{ref}$$

$$R_1 = R_4, R_2 = R_3$$

$$CMR_{R\_error} \approx 20 \log \left( \frac{1 + \frac{R_4}{R_3} + \frac{2R_4}{R_G}}{4R_{error}} \right)$$

Figure 11. Instrumentation Amplifier with two OpAmp

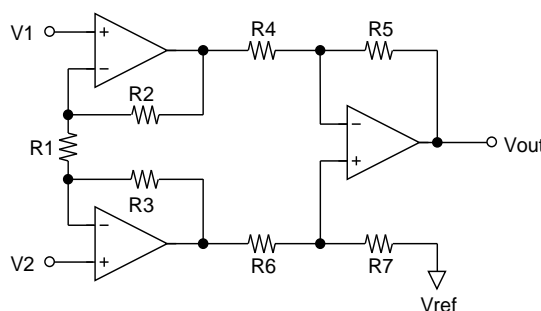

$$V_{out} = \left(1 + \frac{2R_2}{R_1}\right) \left(\frac{R_5}{R_4}\right) (V_2 - V_1) + V_{ref}$$

$$R_2 = R_3, R_4 = R_6, R_5 = R_7$$

$$CMR_{R\_error} \approx 20 \log \left( \frac{R_1 + 2R_2}{R_1} \times \frac{1 + \frac{R_5}{R_4}}{4R_{error}} \right)$$

Figure 12. Instrumentation Amplifier with three OpAmp

**Current Sensing**

Current sensing applications are one such application in a wide range of electronic applications and mostly used for feedback control systems, including power metering battery life indicators and chargers, over-current protection and supervising circuit, automotive, and medical equipment. In such applications, it is desirable to use a shunt with very low resistance to minimize the series voltage drop and minimizes wasted power, and allows the measurement of high current. The NLx333 series is ideal for these current sensing applications.

Figure13 shows a high-side current sensing circuit, and Figure14 shows a low-side current sensing circuit. The NLx333 series has rail-to-rail input and output characteristics, thus allows the both of high-side and low-side current sensing circuit.

The current detection circuit uses a differential amplifier consisting of an OpAmp and resistors R1/R2/R3/R4. The differential amplifier's common-mode rejection ratio (CMR) is primarily determined by resistor mismatches. For details, refer to "differential amplifiers" in the application note.

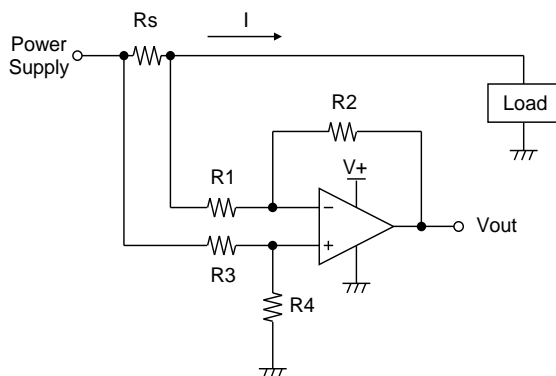

Figure13. High-Side Current Sensing

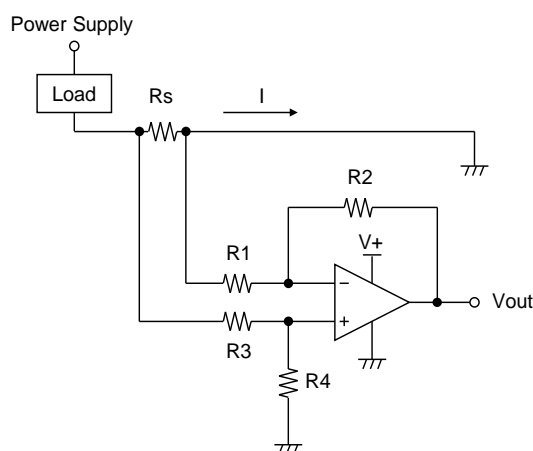

Figure14. Low-Side Current Sensing

**Transimpedance Amplifier**

The features high input impedance with CMOS input and low power can be used for transimpedance amplifier applications shown in Figure15. The output voltage of amplifier is given by the equation  $V_{OUT} = I_{IN} \cdot R_F$ . Since the output voltage swing of amplifier is limited,  $R_F$  should be selected such that all possible values of  $I_{IN}$  can be detected.

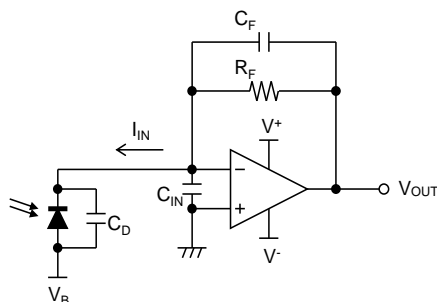

Figure15. Transimpedance amplifier

The  $C_D$ ,  $C_{IN}$  and  $R_F$  generate a phase lag which causes gain-peaking and can destabilized circuit. The essential component for obtaining a maximally flat response is a feedback capacitor  $C_F$ .  $C_F$  is usually added in parallel with  $R_F$  to maintain circuit stability and to control the frequency response. To maximally flat, 2nd order response,  $R_F$  and  $C_F$  should be chosen by using below equation.

$$C_F = \sqrt{\frac{C_{IN} + C_D}{GBW \times 2\pi \times R_F}}$$

### Bridge Amplifier

Bridge sensors for measuring strain, pressure, and temperature are often used in the Wheatstone bridge circuit shown in Figure 16.

Since bridge output signals are typically small, amplifiers may need to operate with high gain, low offset voltage, drift, and low noise.

In addition, the bridge output signal is differential, so amplifier circuits are typically used with differential amplifiers or Instrumentation Amplifiers.

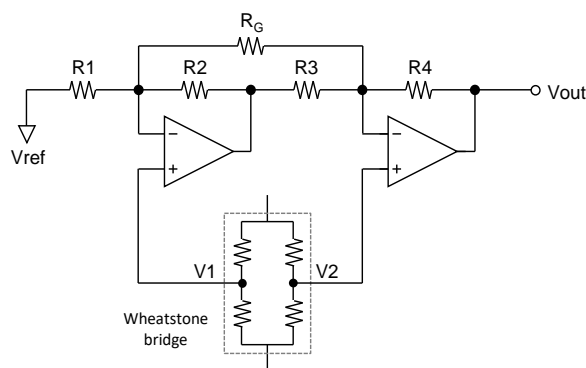

Figure 16. Bridge Amplifier

**EMIRR (EMI Rejection Ratio) Definition**

EMIRR is a parameter indicating the EMI robustness of an OpAmp. The definition of EMIRR is given by the following equation1.

The tolerance of the RF signal can be grasped by measuring an RF signal and offset voltage shift quantity. Offset voltage shift is small so that a value of EMIRR is big. And it understands that the tolerance for the RF signal is high. In addition, about the input offset voltage shift with the RF signal, there is the thinking that influence applied to the input terminal is dominant. Therefore, generally the EMIRR becomes value that applied an RF signal to +INPUT terminal.

$$EMIRR = 20 \cdot \log \left( \frac{V_{RF\_PEAK}}{|\Delta V_{IO}|} \right) \quad \text{--- eq.1}$$

$V_{RF\_PEAK}$ : RF Signal Amplitude [VP]

$\Delta V_{IO}$ : Input offset voltage shift quantity [V]

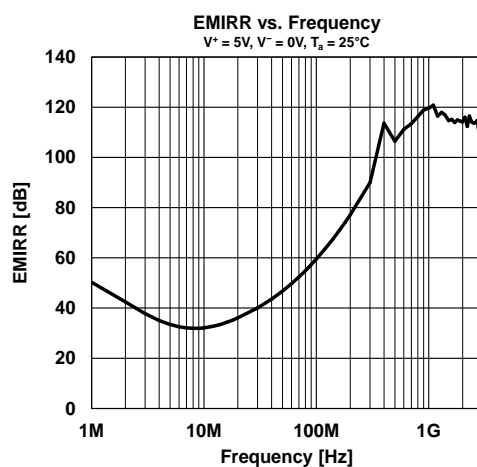

\*For details, refer to "Application Note for EMI Immunity" in our HP.

■ MARKING SPECIFICATION (SOT-23-5-DC)

- ①②③      Product Code      Refer to *Part Marking List*
- ④⑤      Lot Number      Alphanumeric Serial Number

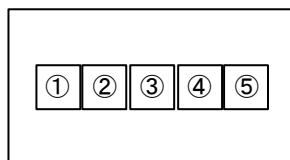

1Pin

**NOTICE**

There can be variation in the marking when different AOI (Automated Optical Inspection) equipment is used. In the case of recognizing the marking characteristic with AOI, please contact our sales or distributor before attempting to use AOI.

**Part Marking List**

Product Name	①	②	③
NL0333DCAE1S	A	1	2

■ MARKING SPECIFICATION (SC-88A-DB)

②③	Product Code	Refer to <i>Part Marking List</i>
①④⑤	Lot Number	Alphanumeric Serial Number

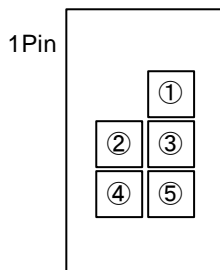

**NOTICE**

There can be variation in the marking when different AOI (Automated Optical Inspection) equipment is used. In the case of recognizing the marking characteristic with AOI, please contact our sales or distributor before attempting to use AOI.

**Part Marking List**

Product Name	②	③
NL1333DBAE1S	S	2

■ MARKING SPECIFICATION (VSP-8-AF)

- ① to ⑦      Product Code      Refer to *Part Marking List*
- ⑧ to ⑫      Lot Number            Alphanumeric Serial Number

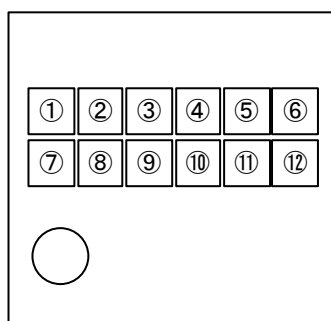

1Pin

**NOTICE**

There can be variation in the marking when different AOI (Automated Optical Inspection) equipment is used. In the case of recognizing the marking characteristic with AOI, please contact our sales or distributor before attempting to use AOI.

**Part Marking List**

Product Name	①	②	③	④	⑤	⑥	⑦
NL2333AFAE2S	L	2	3	3	3	A	S

■ MARKING SPECIFICATION (EMP-8-AN)

- ① to ⑦      Product Code      Refer to *Part Marking List*
- ⑧ to ⑫      Lot Number              Alphanumeric Serial Number

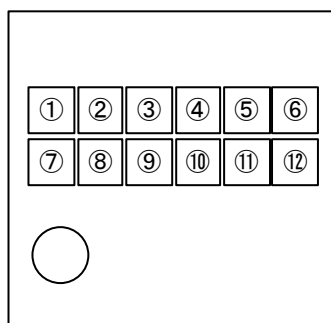

1Pin

**NOTICE**

There can be variation in the marking when different AOI (Automated Optical Inspection) equipment is used. In the case of recognizing the marking characteristic with AOI, please contact our sales or distributor before attempting to use AOI.

**Part Marking List**

Product Name	①	②	③	④	⑤	⑥	⑦
NL2333ANAE2S	L	2	3	3	3	A	S

■ PACKAGE DIMENSIONS

UNIT: mm

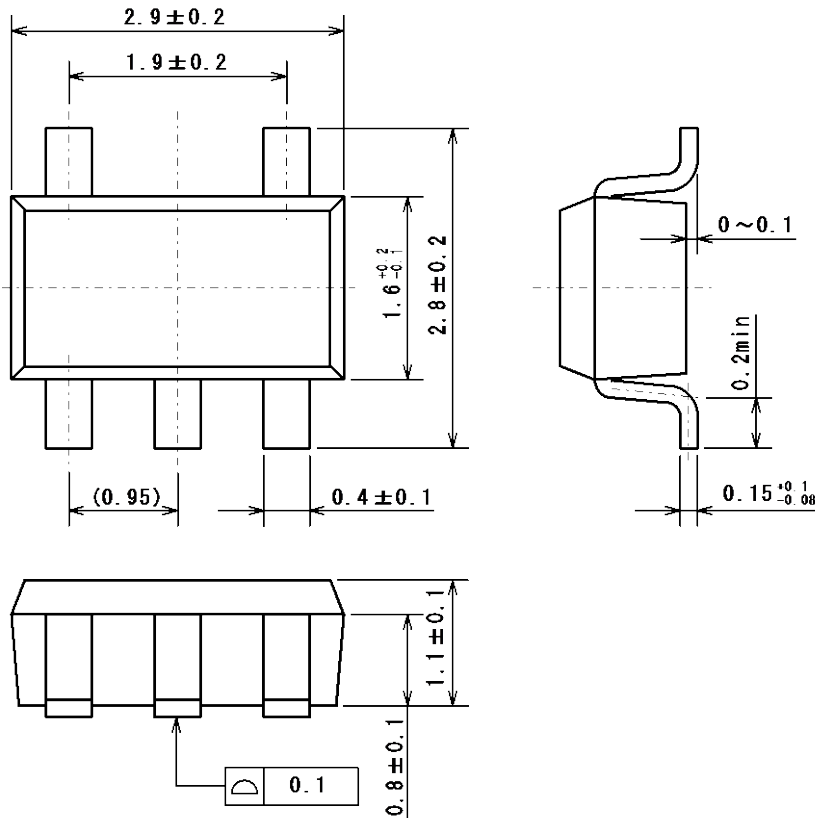

■ EXAMPLE OF SOLDER PADS DIMENSIONS

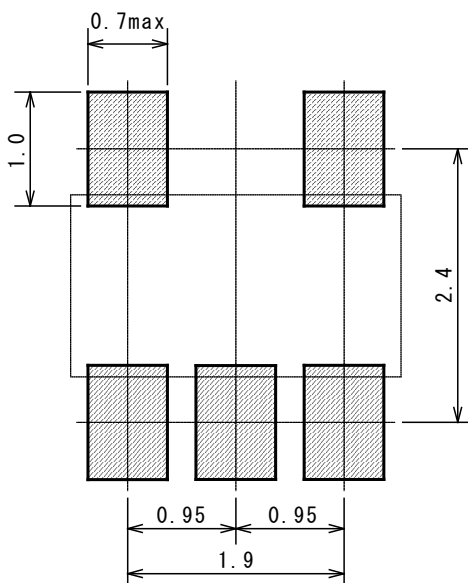

Nisshinbo Micro Devices Inc.

SOT-23-5-DC

PI-SOT-23-5-DC-02-E-A

■ PACKING SPEC

UNIT: mm

(1) Taping dimensions / Insert direction

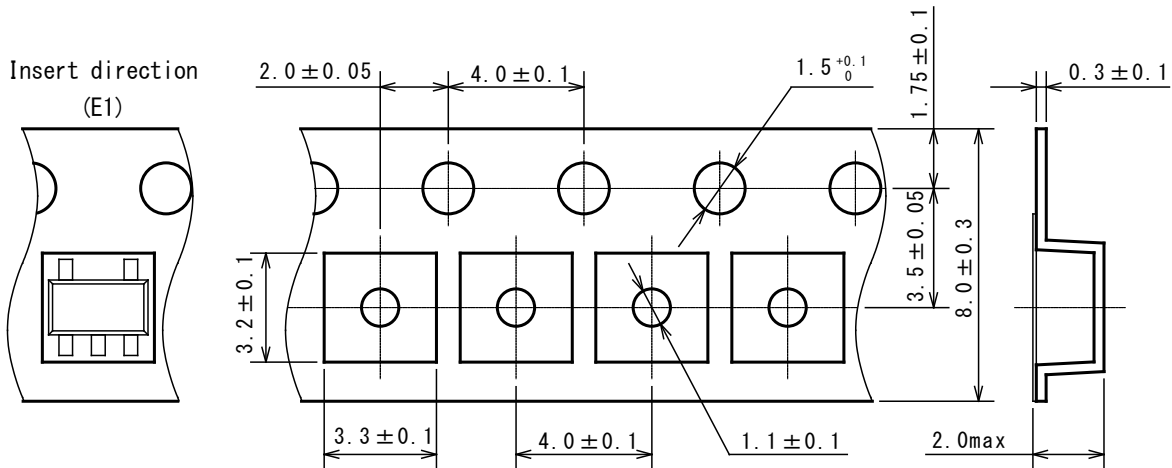

(2) Taping state

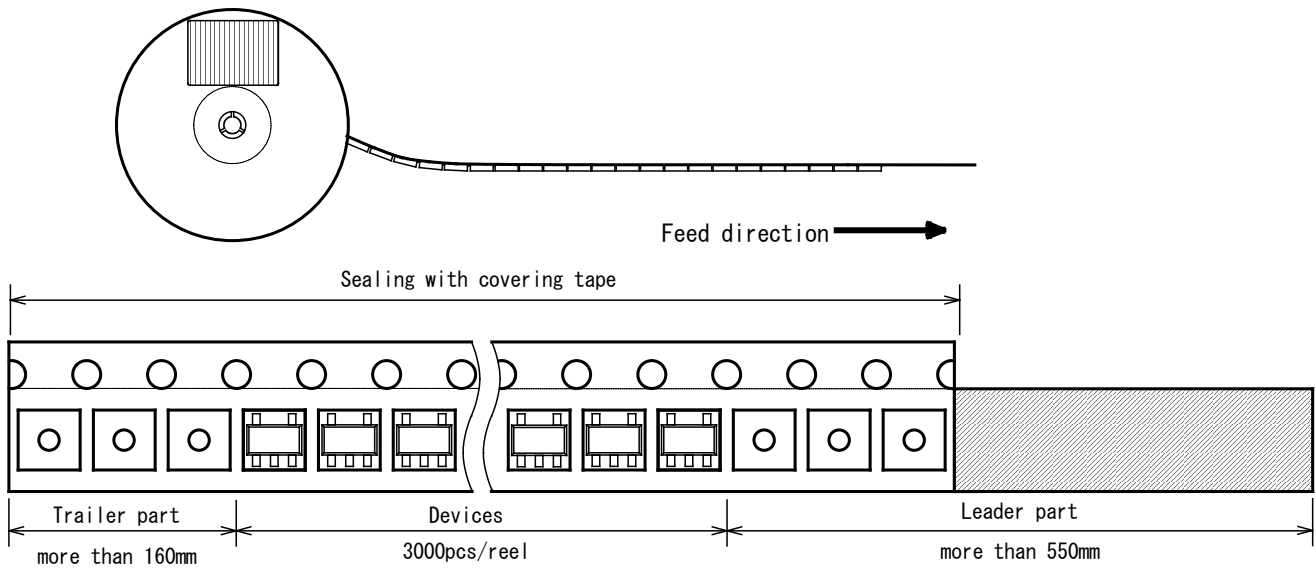

(3) Reel dimensions

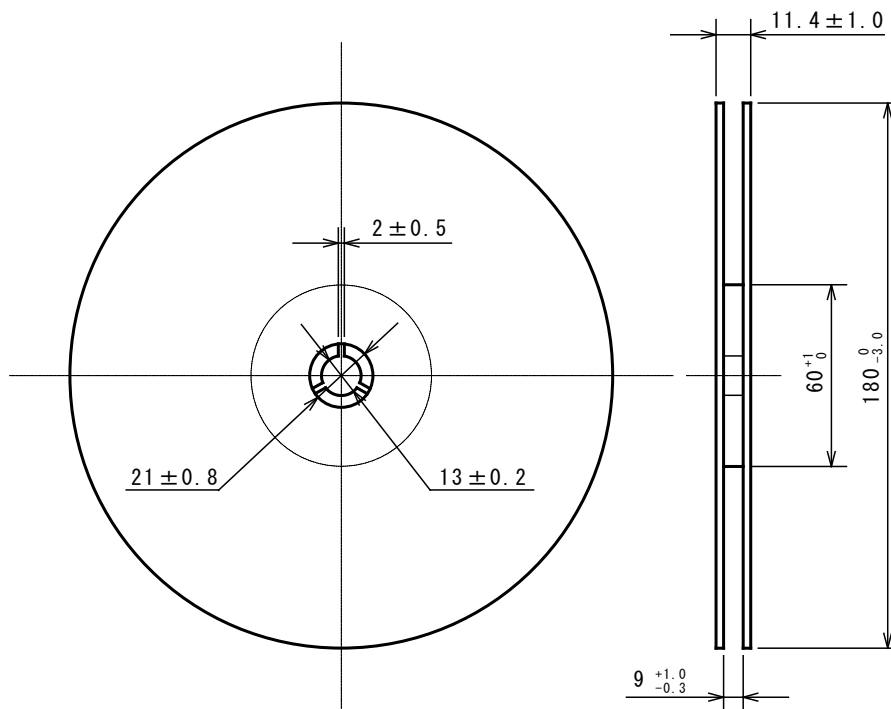

(4) Peeling strength

Peeling strength of cover tape

- Peeling angle 165 to 180° degrees to the taped surface.
- Peeling speed 300mm/min
- Peeling strength 0.1 to 1.0N

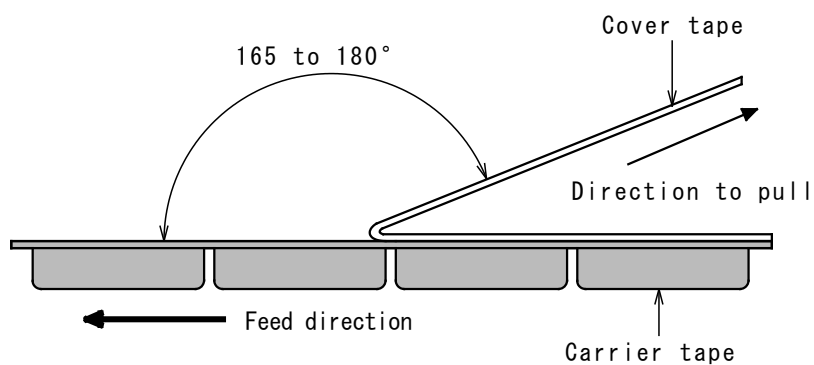

(5) Packing state

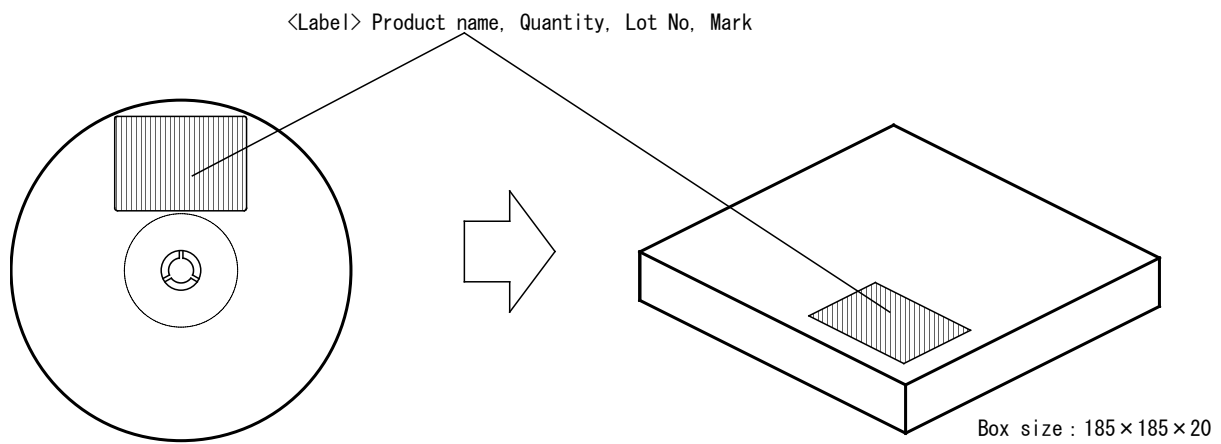

■ HEAT-RESISTANCE PROFILES

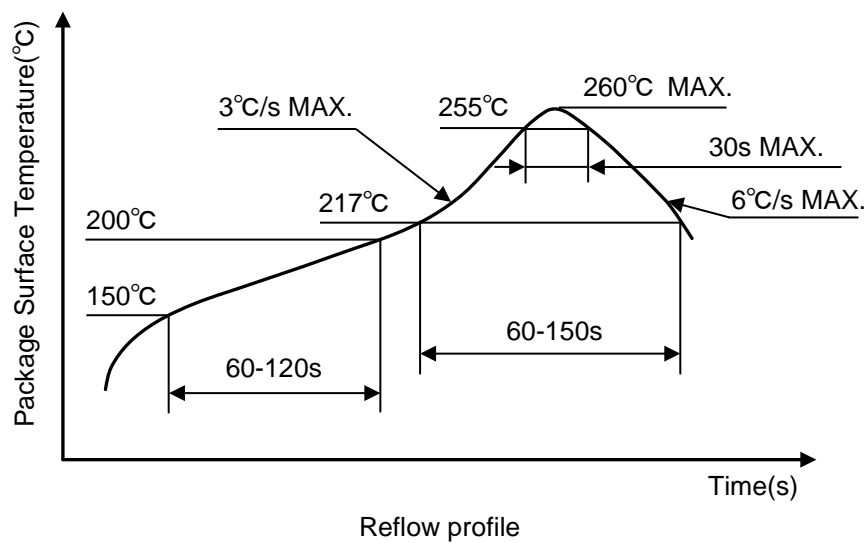

■ PACKAGE DIMENSIONS

UNIT: mm

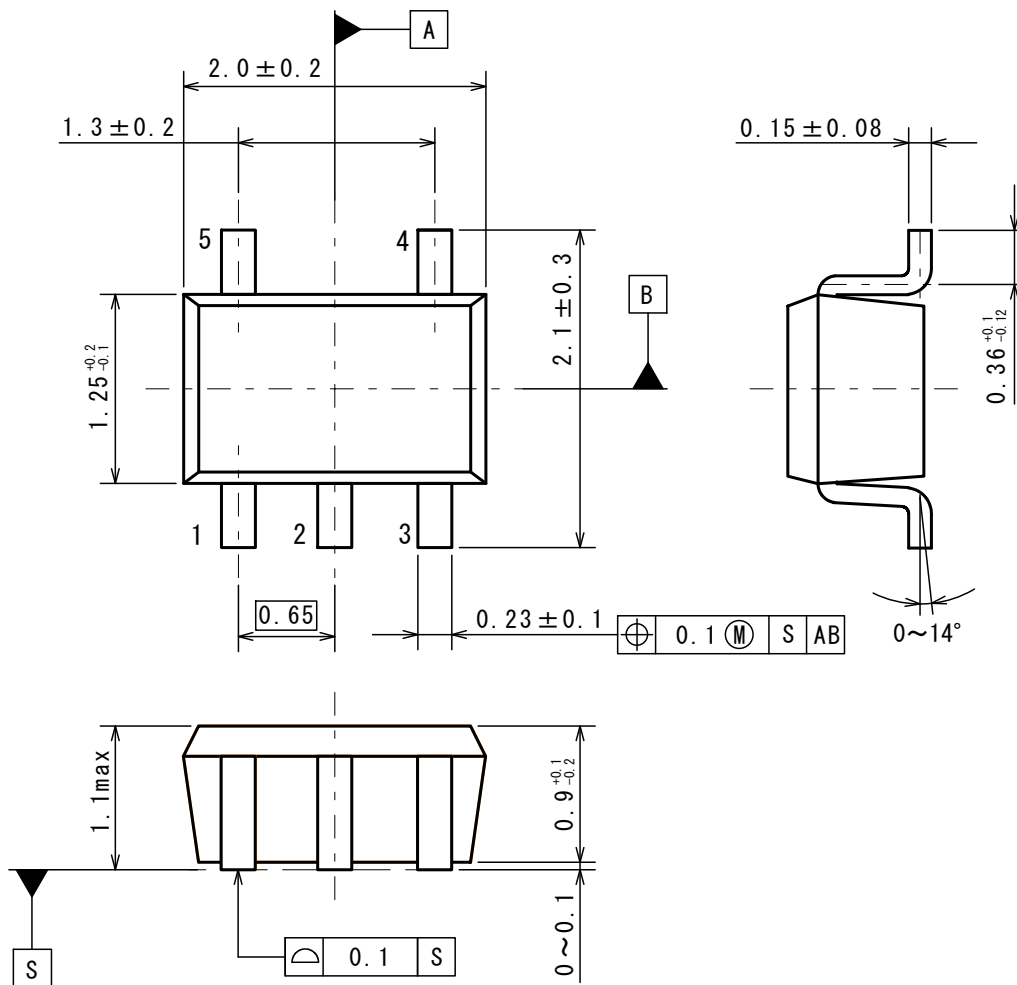

■ EXAMPLE OF SOLDER PADS DIMENSIONS

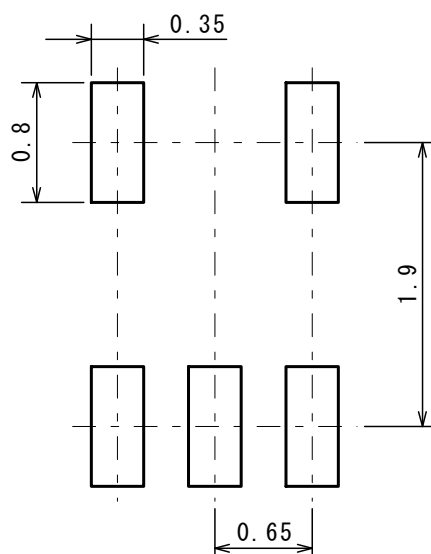

# Nisshinbo Micro Devices Inc.

SC-88A-DB

PI-SC-88A-DB-02-E-A

■ PACKING SPEC

UNIT: mm

(1) Taping dimensions / Insert direction

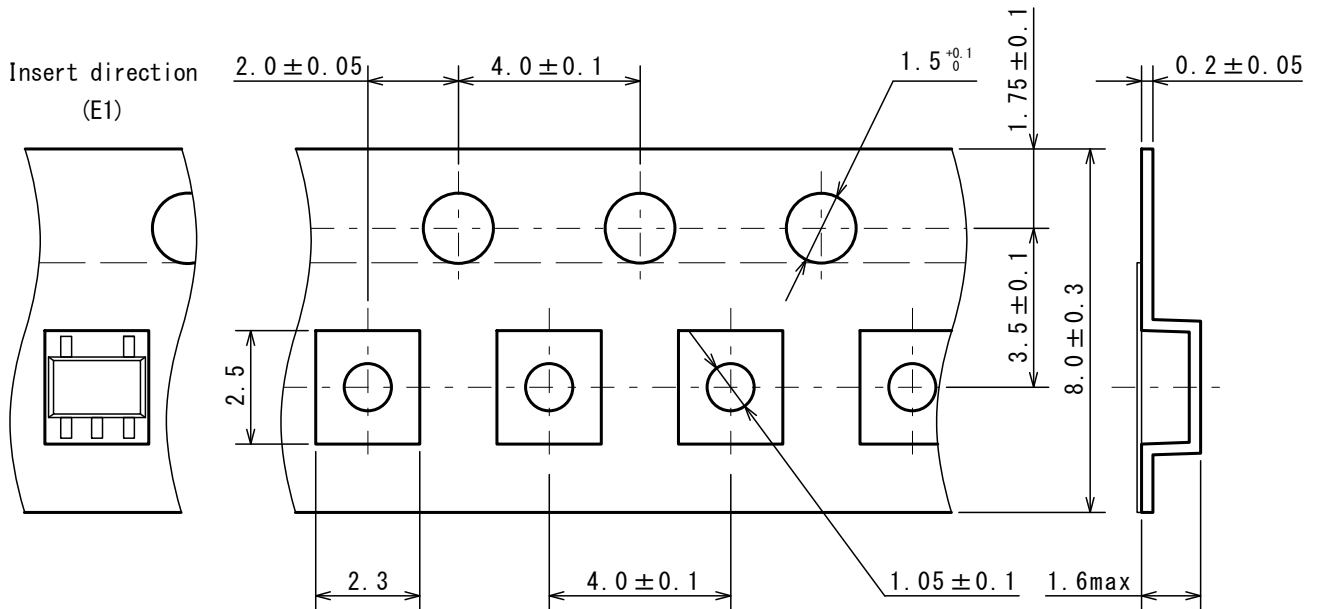

(2) Taping state

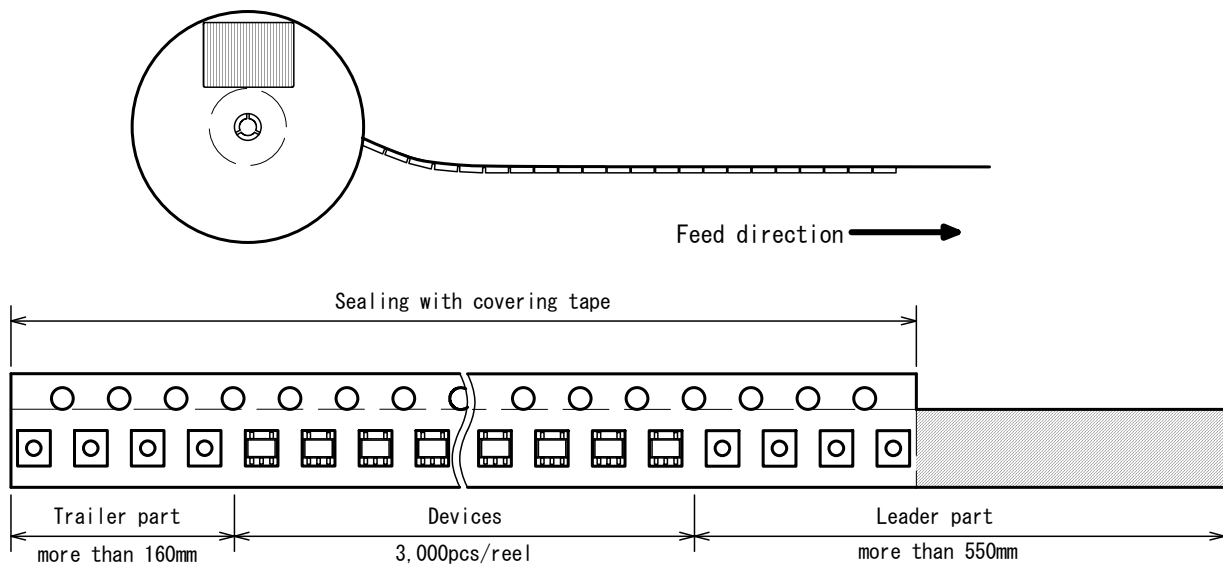

## (3) Reel dimensions

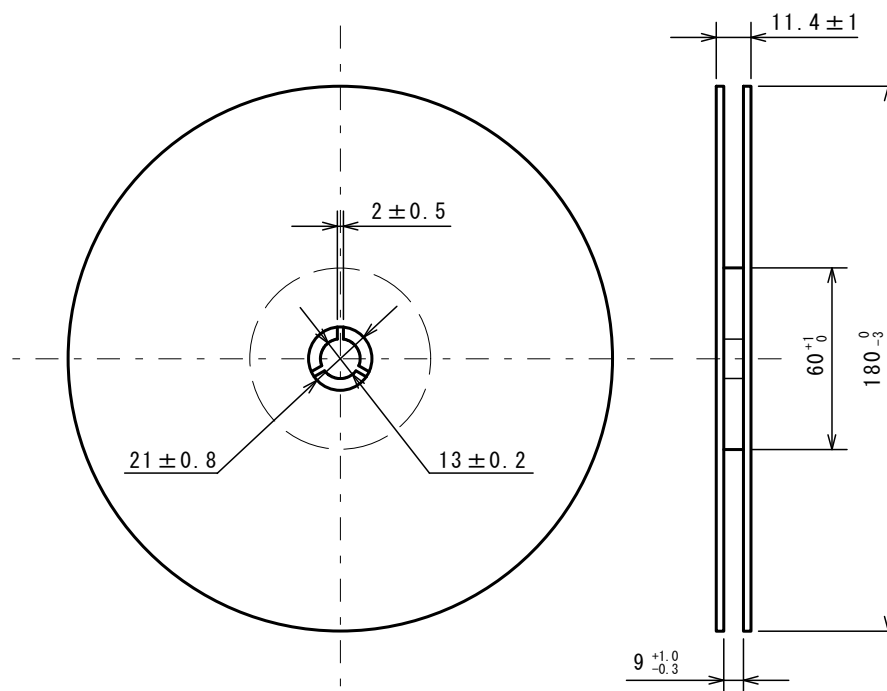

## (4) Peeling strength

Peeling strength of cover tape

- Peeling angle  $165$  to  $180^\circ$  degrees to the taped surface.
- Peeling speed  $300\text{mm}/\text{min}$
- Peeling strength  $0.1$  to  $1.0\text{N}$

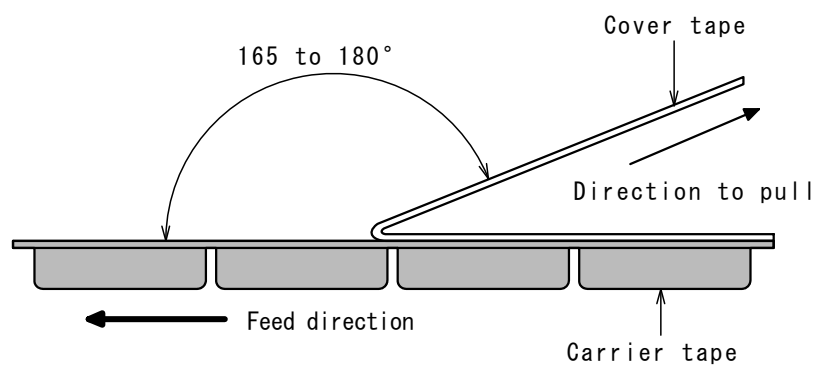

(5) Packing state

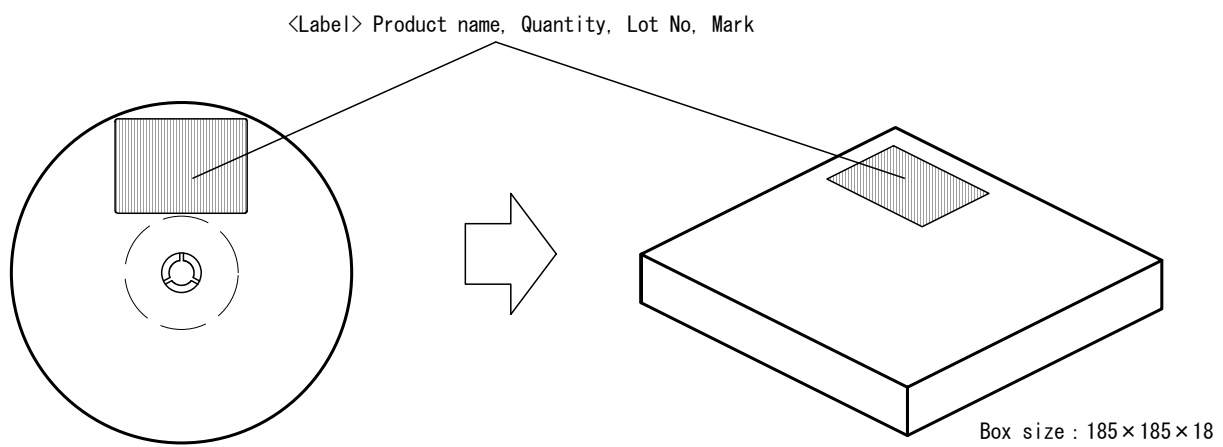

■ HEAT-RESISTANCE PROFILES

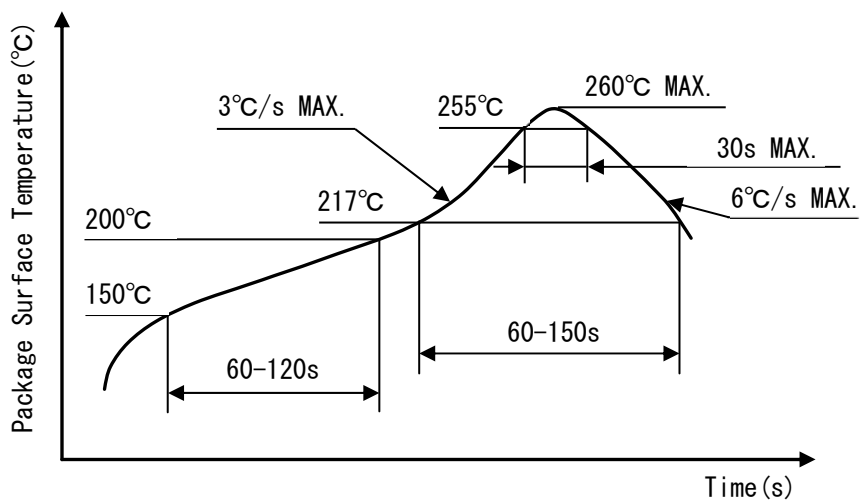

Reflow profile

# Nisshinbo Micro Devices Inc.

VSP-8-AF

PI-VSP-8-AF-E-A

## ■ PACKAGE DIMENSIONS

UNIT: mm

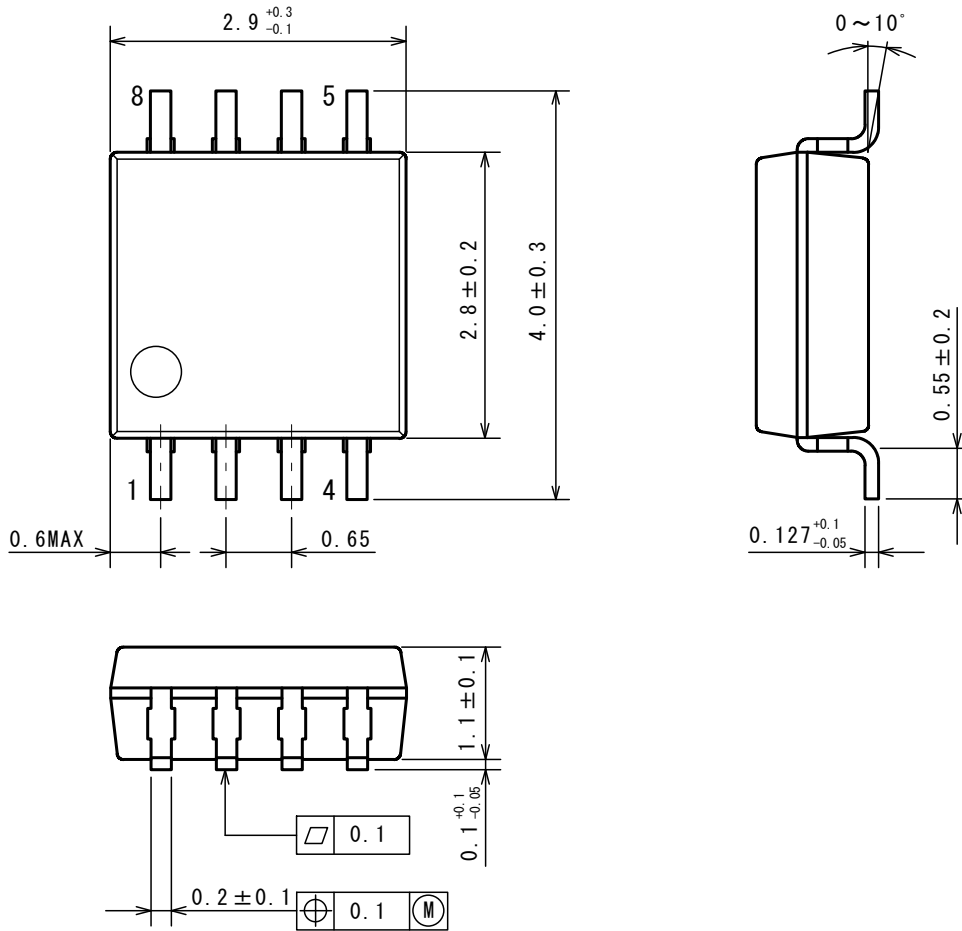

## ■ EXAMPLE OF SOLDER PADS DIMENSIONS

UNIT: mm

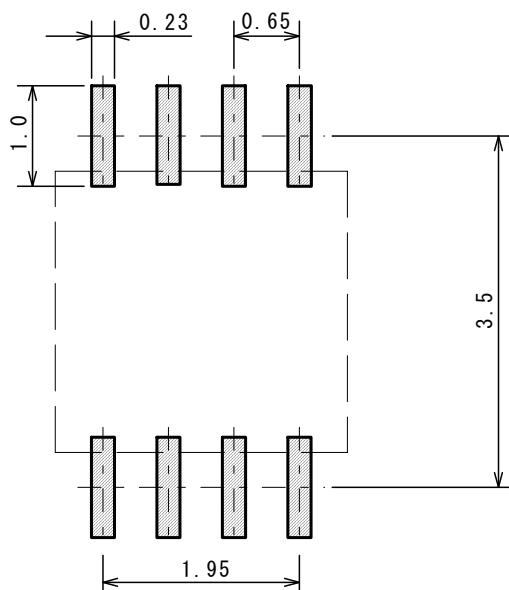

# Nisshinbo Micro Devices Inc.

VSP-8-AF

PI-VSP-8-AF-E-A

## ■ PACKING SPEC

UNIT: mm

### (1) Taping dimensions / Insert direction

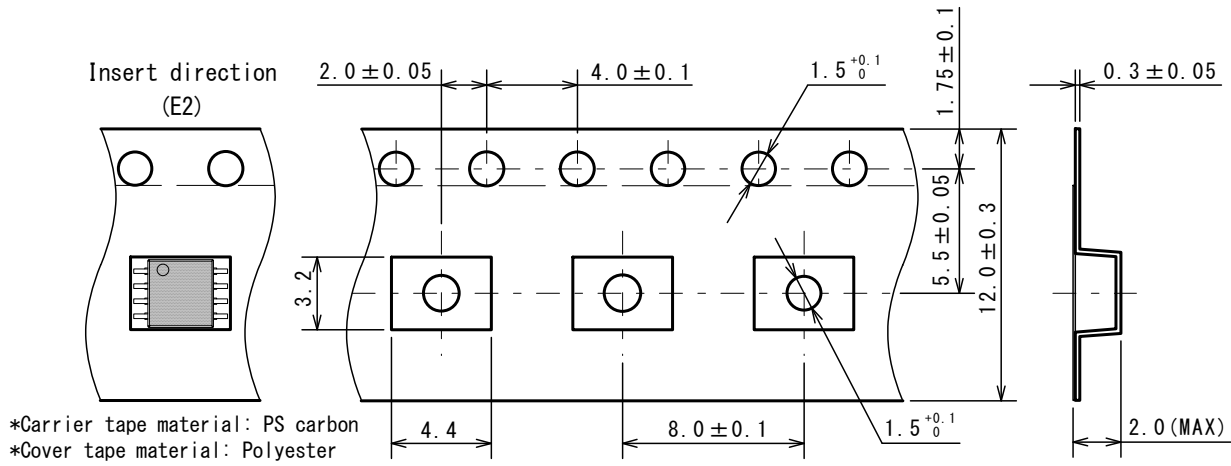

### (2) Taping state

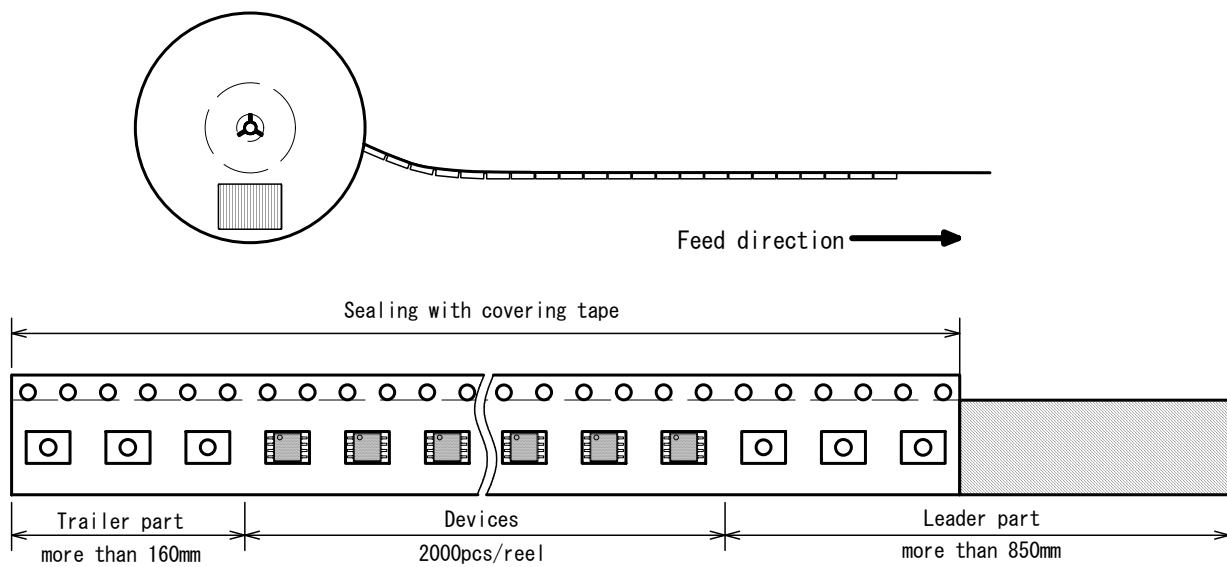

# Nisshinbo Micro Devices Inc.

VSP-8-AF

PI-VSP-8-AF-E-A

## (3) Reel dimensions

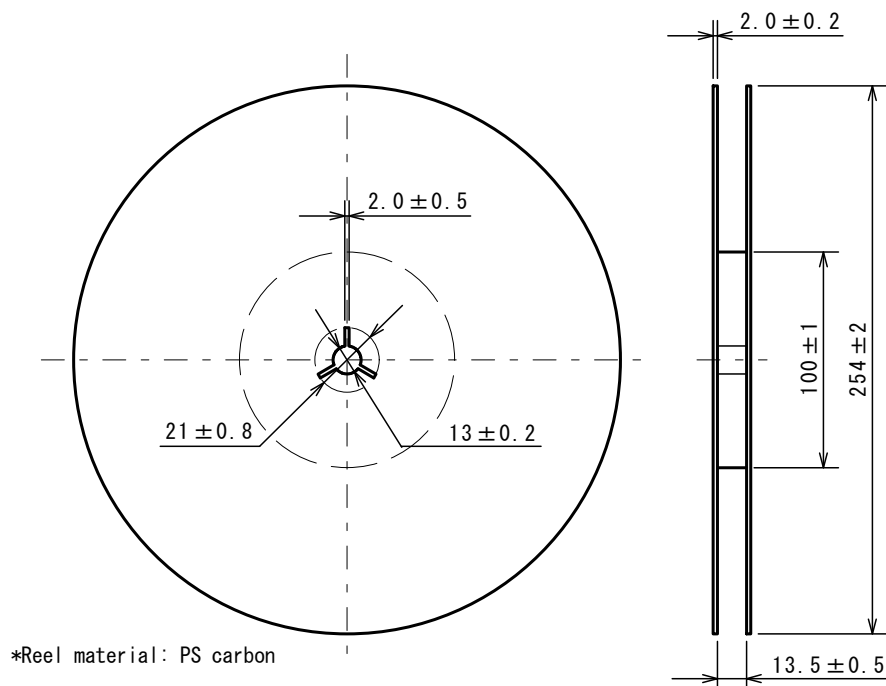

## (4) Peeling strength

Peeling strength of cover tape

- Peeling angle  $165$  to  $180^\circ$  degrees to the taped surface.
- Peeling speed  $300\text{mm}/\text{min}$
- Peeling strength  $0.1$  to  $1.3\text{N}$

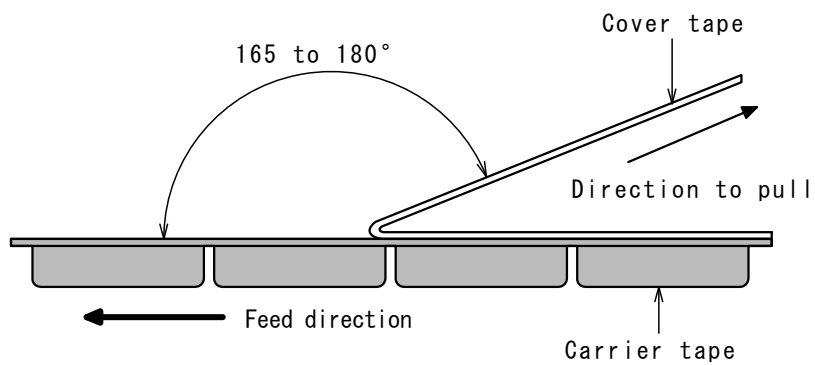

(5) Packing state

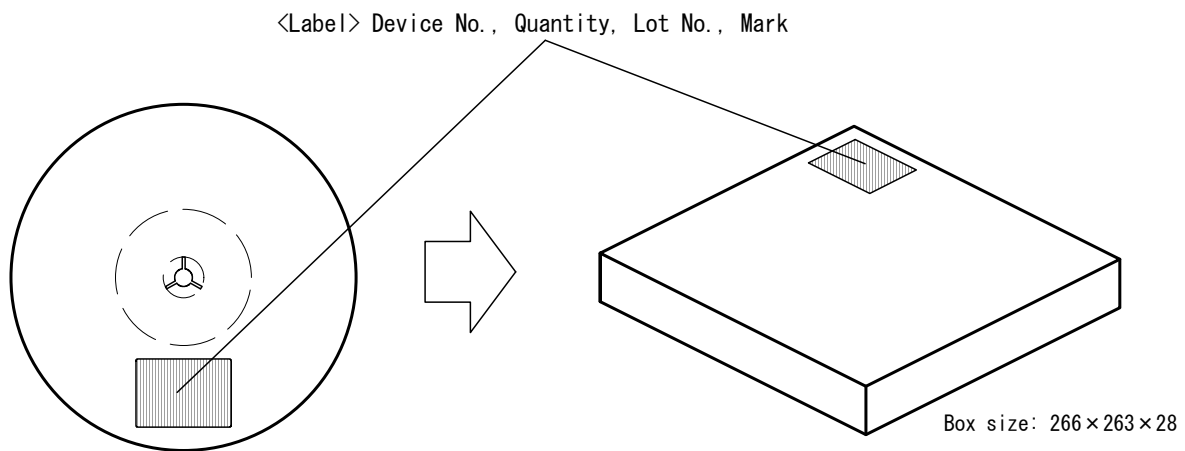

■ HEAT-RESISTANCE PROFILES

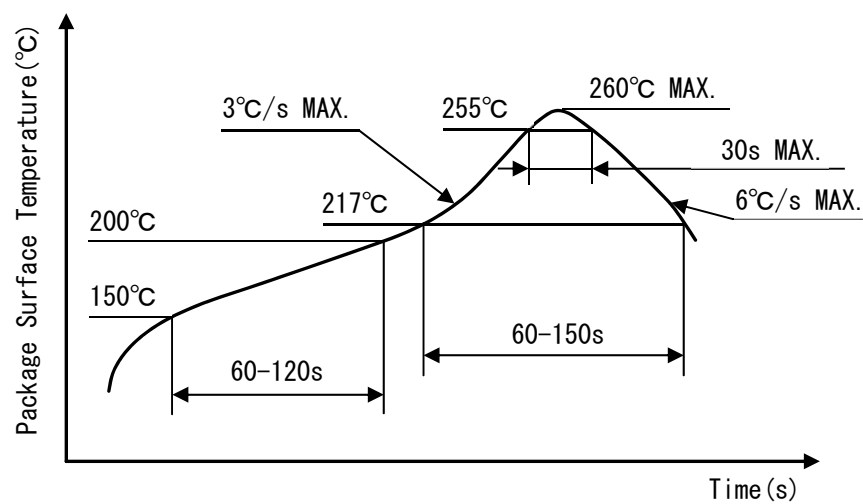

Reflow profile

# Nisshinbo Micro Devices Inc.

EMP-8-AN

PI-EMP-8-AN-E-A

## ■ PACKAGE DIMENSIONS

UNIT: mm

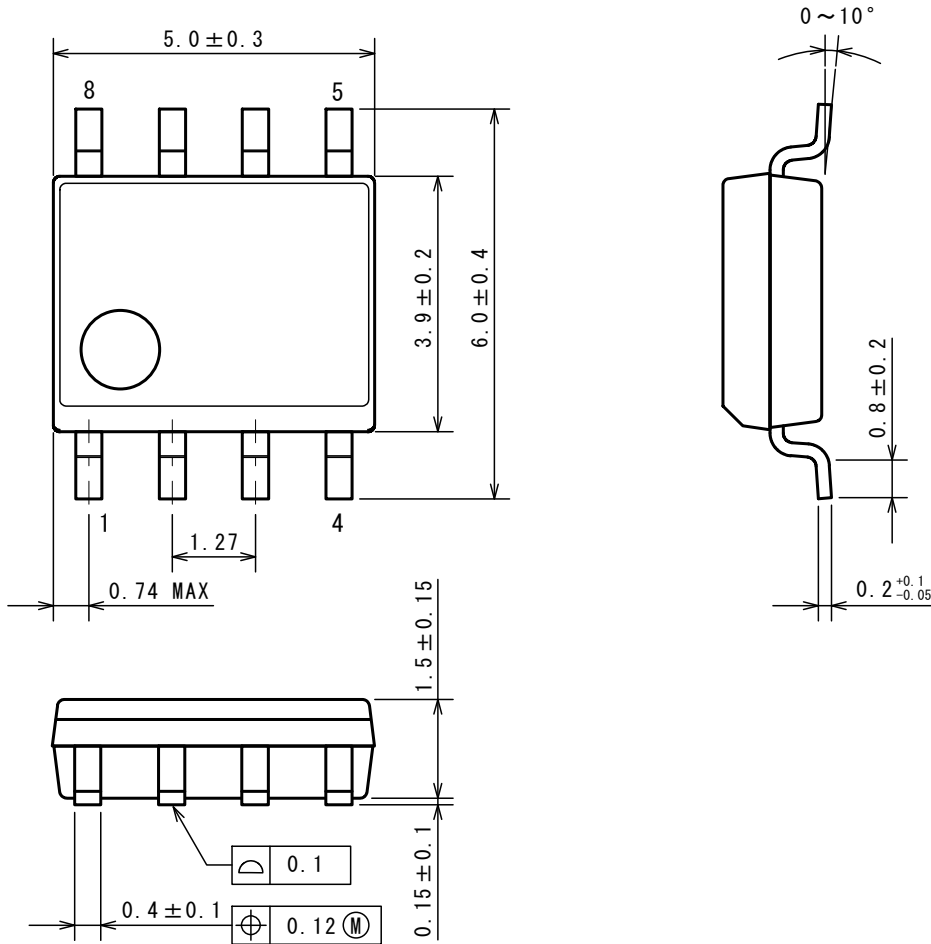

## ■ EXAMPLE OF SOLDER PADS DIMENSIONS

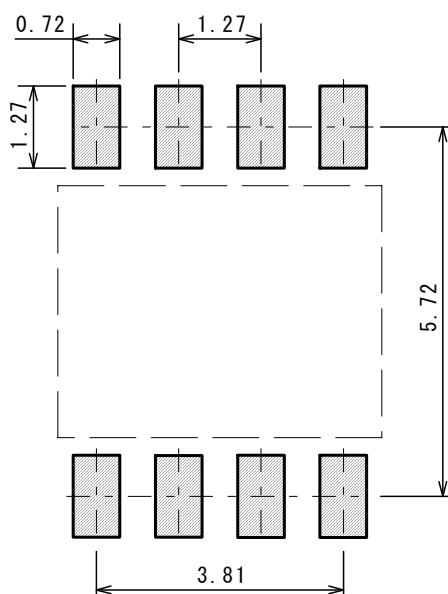

# Nisshinbo Micro Devices Inc.

EMP-8-AN

PI-EMP-8-AN-E-A

## ■ PACKING SPEC

UNIT: mm

### (1) Taping dimensions / Insert direction

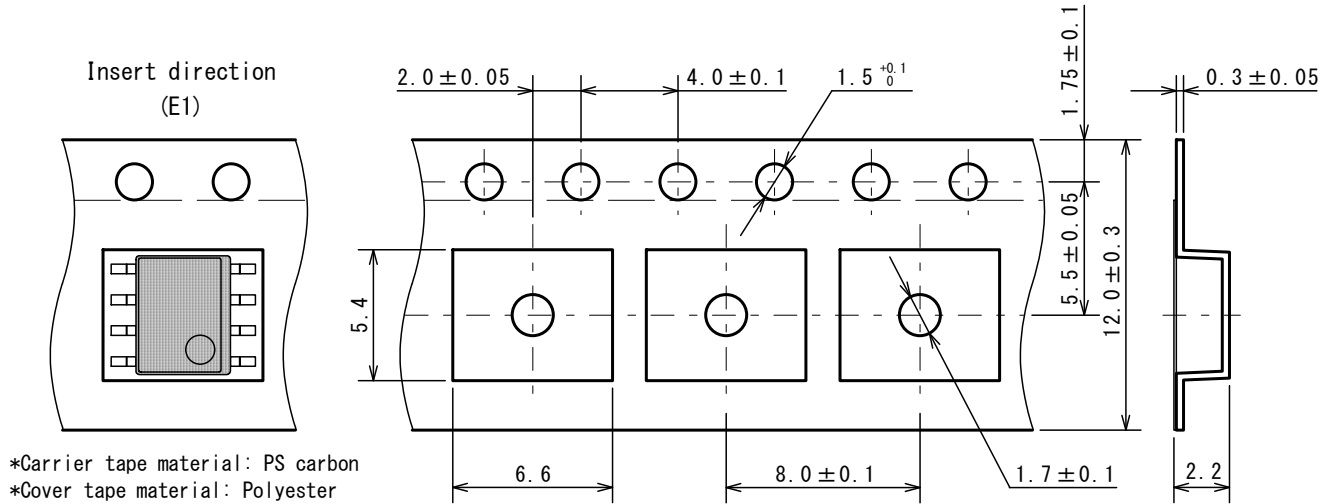

### (2) Taping state

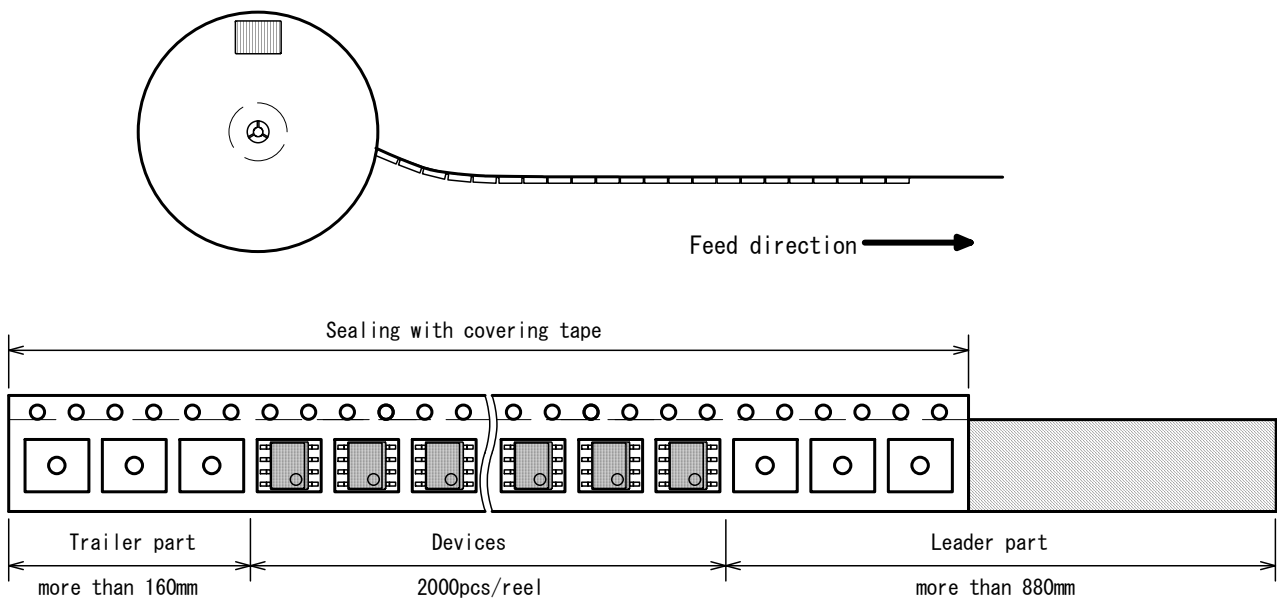

(3) Reel dimensions

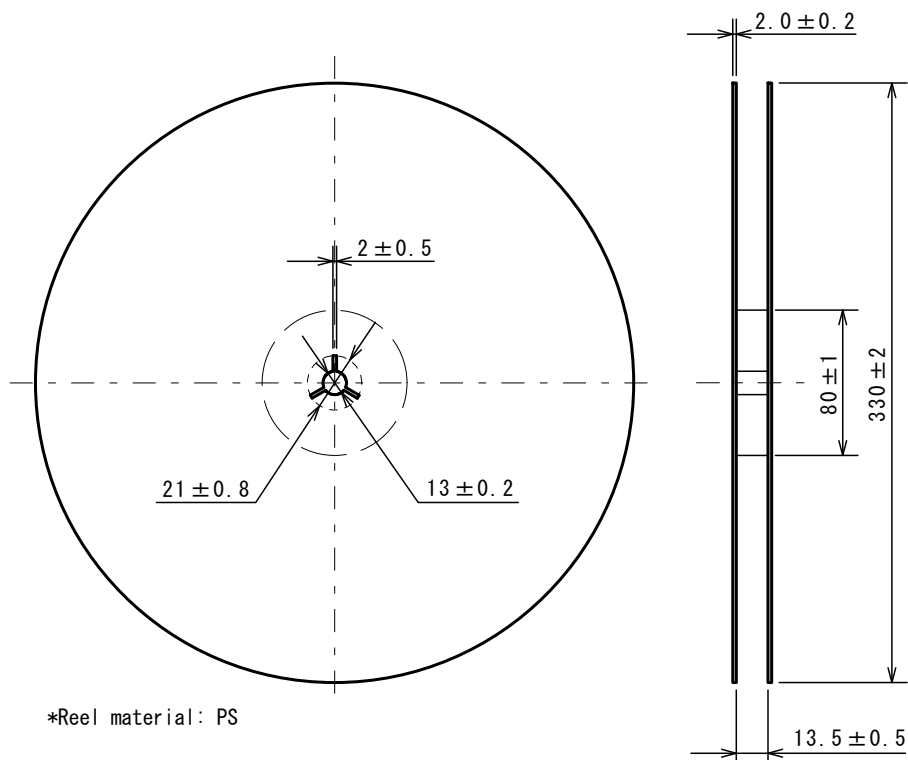

(4) Peeling strength

Peeling strength of cover tape

- Peeling angle 165 to 180° degrees to the taped surface.
- Peeling speed 300mm/min
- Peeling strength 0.1 to 1.3N

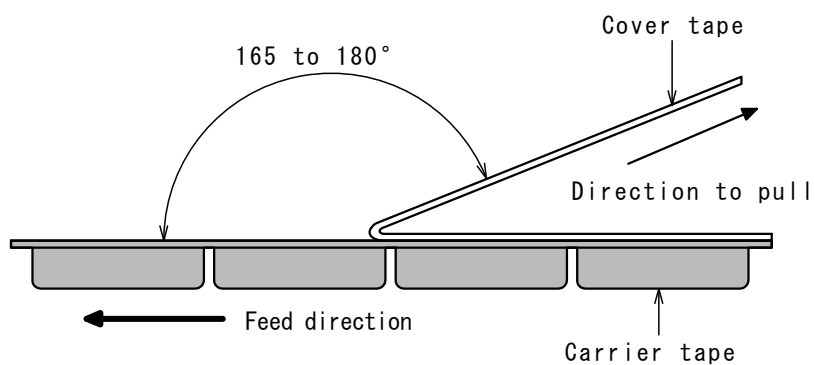

(5) Packing state

<Label> Device No., Quantity, Lot No., Mark

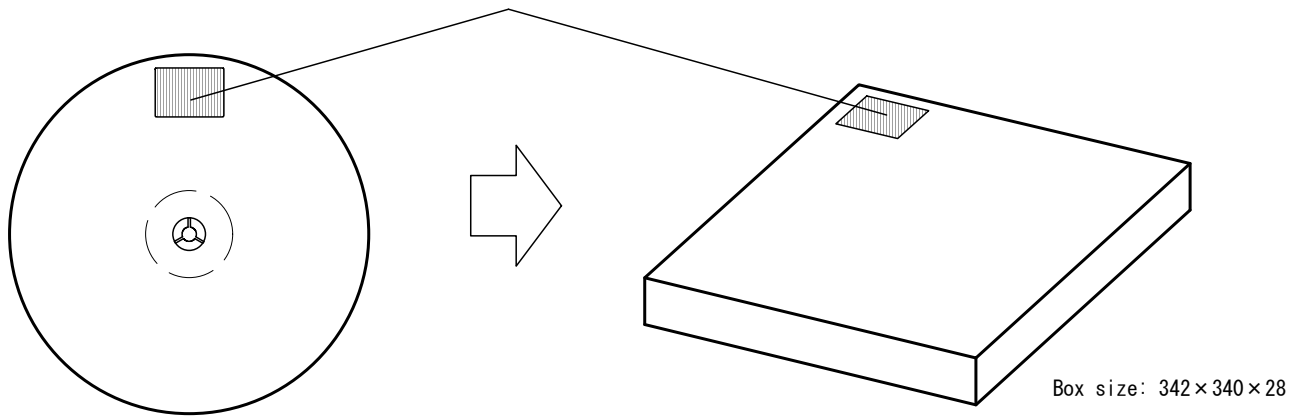

■ HEAT-RESISTANCE PROFILES

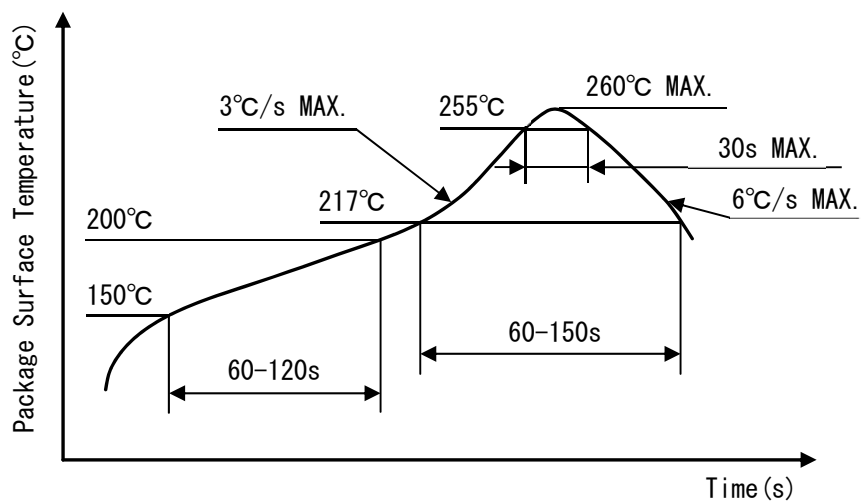

Reflow profile

## ■ REVISION HISTORY

Date	Revision	Contents of Changes
March 20, 2025	Ver.1.0	Initial Release.

1. The products and the product specifications described in this document are subject to change or discontinuation of production without notice for reasons such as improvement. Therefore, before deciding to use the products, please refer to our sales representatives for the latest information thereon.
2. The materials in this document may not be copied or otherwise reproduced in whole or in part without the prior written consent of us.
3. This product and any technical information relating thereto are subject to complementary export controls (so-called KNOW controls) under the Foreign Exchange and Foreign Trade Law, and related politics ministerial ordinance of the law. (Note that the complementary export controls are inapplicable to any application-specific products, except rockets and pilotless aircraft, that are insusceptible to design or program changes.) Accordingly, when exporting or carrying abroad this product, follow the Foreign Exchange and Foreign Trade Control Law and its related regulations with respect to the complementary export controls.
4. The technical information described in this document shows typical characteristics and example application circuits for the products. The release of such information is not to be construed as a warranty of or a grant of license under our or any third party's intellectual property rights or any other rights.
5. The products listed in this document are intended and designed for use as general electronic components in standard applications (office equipment, telecommunication equipment, measuring instruments, consumer electronic products, amusement equipment etc.). Those customers intending to use a product in an application requiring extreme quality and reliability, for example, in a highly specific application where the failure or misoperation of the product could result in human injury or death should first contact us.
  - Aerospace Equipment
  - Equipment Used in the Deep Sea
  - Power Generator Control Equipment (nuclear, steam, hydraulic, etc.)
  - Life Maintenance Medical Equipment
  - Fire Alarms / Intruder Detectors
  - Vehicle Control Equipment (automotive, airplane, railroad, ship, etc.)
  - Various Safety Devices
  - Traffic control system
  - Combustion equipment

In case your company desires to use this product for any applications other than general electronic equipment mentioned above, make sure to contact our company in advance. Note that the important requirements mentioned in this section are not applicable to cases where operation requirements such as application conditions are confirmed by our company in writing after consultation with your company.

6. We are making our continuous effort to improve the quality and reliability of our products, but semiconductor products are likely to fail with certain probability. In order to prevent any injury to persons or damages to property resulting from such failure, customers should be careful enough to incorporate safety measures in their design, such as redundancy feature, fire containment feature and fail-safe feature. We do not assume any liability or responsibility for any loss or damage arising from misuse or inappropriate use of the products.
7. The products have been designed and tested to function within controlled environmental conditions. Do not use products under conditions that deviate from methods or applications specified in this datasheet. Failure to employ the products in the proper applications can lead to deterioration, destruction or failure of the products. We shall not be responsible for any bodily injury, fires or accident, property damage or any consequential damages resulting from misuse or misapplication of the products.
8. **Quality Warranty**
  - 8-1. **Quality Warranty Period**

In the case of a product purchased through an authorized distributor or directly from us, the warranty period for this product shall be one (1) year after delivery to your company. For defective products that occurred during this period, we will take the quality warranty measures described in section 8-2. However, if there is an agreement on the warranty period in the basic transaction agreement, quality assurance agreement, delivery specifications, etc., it shall be followed.
  - 8-2. **Quality Warranty Remedies**

When it has been proved defective due to manufacturing factors as a result of defect analysis by us, we will either deliver a substitute for the defective product or refund the purchase price of the defective product.

Note that such delivery or refund is sole and exclusive remedies to your company for the defective product.
  - 8-3. **Remedies after Quality Warranty Period**

With respect to any defect of this product found after the quality warranty period, the defect will be analyzed by us. On the basis of the defect analysis results, the scope and amounts of damage shall be determined by mutual agreement of both parties. Then we will deal with upper limit in Section 8-2. This provision is not intended to limit any legal rights of your company.
9. Anti-radiation design is not implemented in the products described in this document.
10. The X-ray exposure can influence functions and characteristics of the products. Confirm the product functions and characteristics in the evaluation stage.
11. WLCSP products should be used in light shielded environments. The light exposure can influence functions and characteristics of the products under operation or storage.
12. Warning for handling Gallium and Arsenic (GaAs) products (Applying to GaAs MMIC, Photo Reflector). These products use Gallium (Ga) and Arsenic (As) which are specified as poisonous chemicals by law. For the prevention of a hazard, do not burn, destroy, or process chemically to make them as gas or power. When the product is disposed of, please follow the related regulation and do not mix this with general industrial waste or household waste.
13. Please contact our sales representatives should you have any questions or comments concerning the products or the technical information.



**Nisshinbo Micro Devices Inc.**

**Official website**

<https://www.nisshinbo-microdevices.co.jp/en/>

**Purchase information**

<https://www.nisshinbo-microdevices.co.jp/en/buy/>